



Systematic Uncertainties in Accelerator Neutrino Oscillation Measurements

David Hadley on behalf of the T2K collaboration
27th September 2017

International Workshop on Neutrinos from Accelerators, NUFACT2017



WARWICK
THE UNIVERSITY OF WARWICK

Accelerator based Neutrino Oscillation Experiments

WARWICK
THE UNIVERSITY OF WARWICK

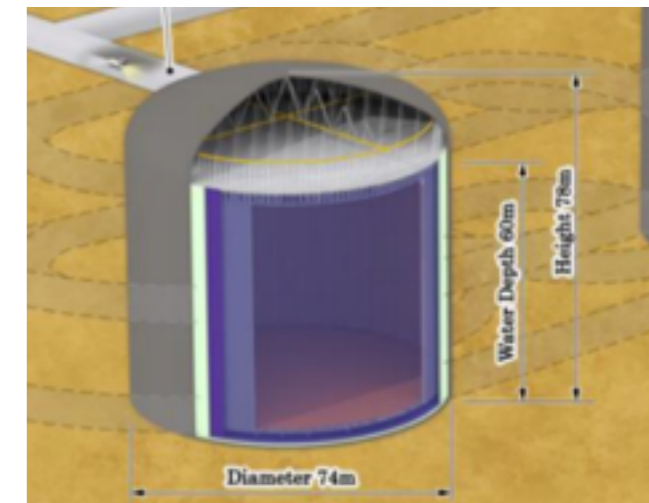
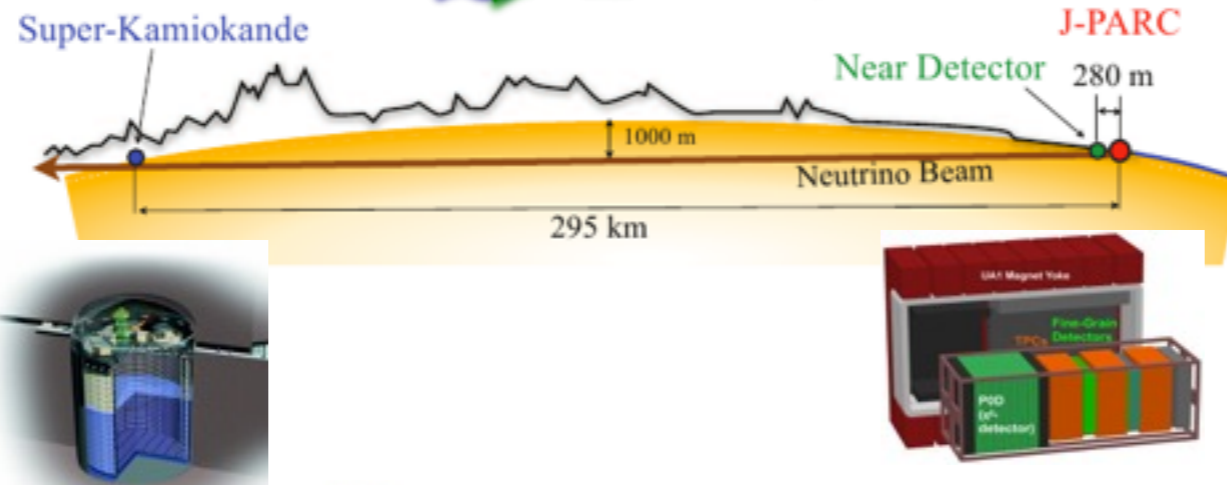
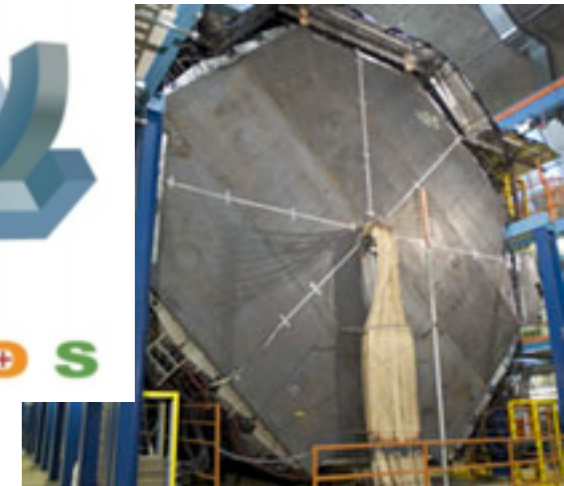
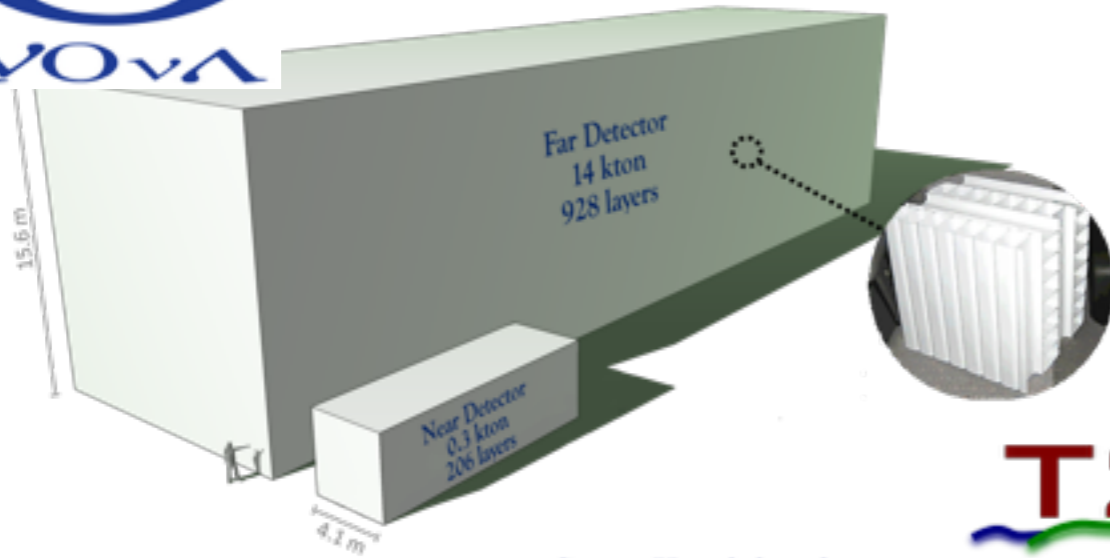

ICARUS

μ BooNE

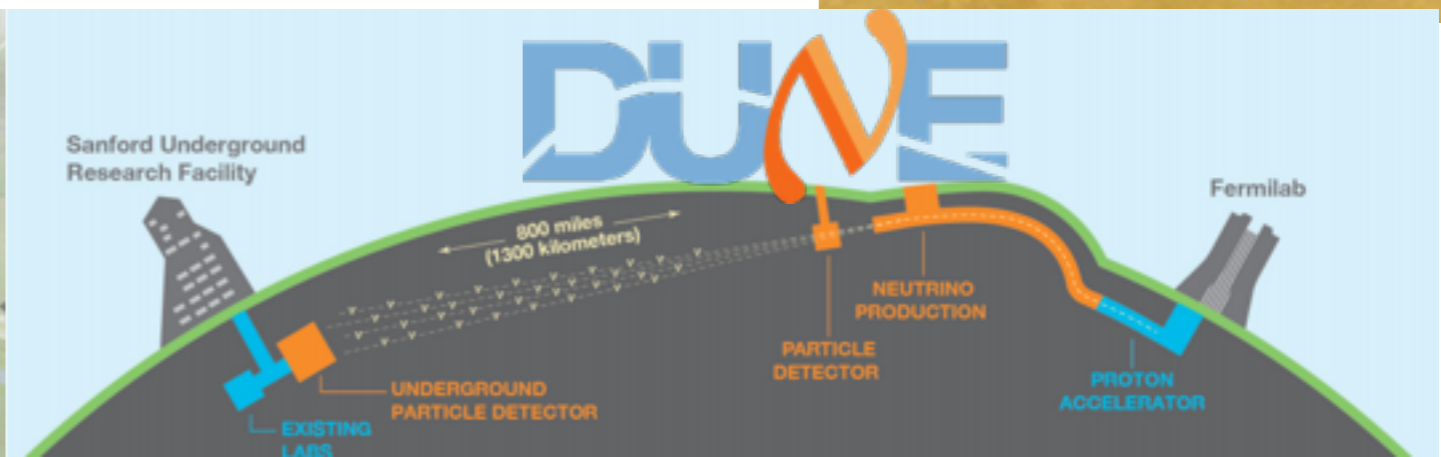

Accelerator based Neutrino Oscillation Experiments

WARWICK
THE UNIVERSITY OF WARWICK

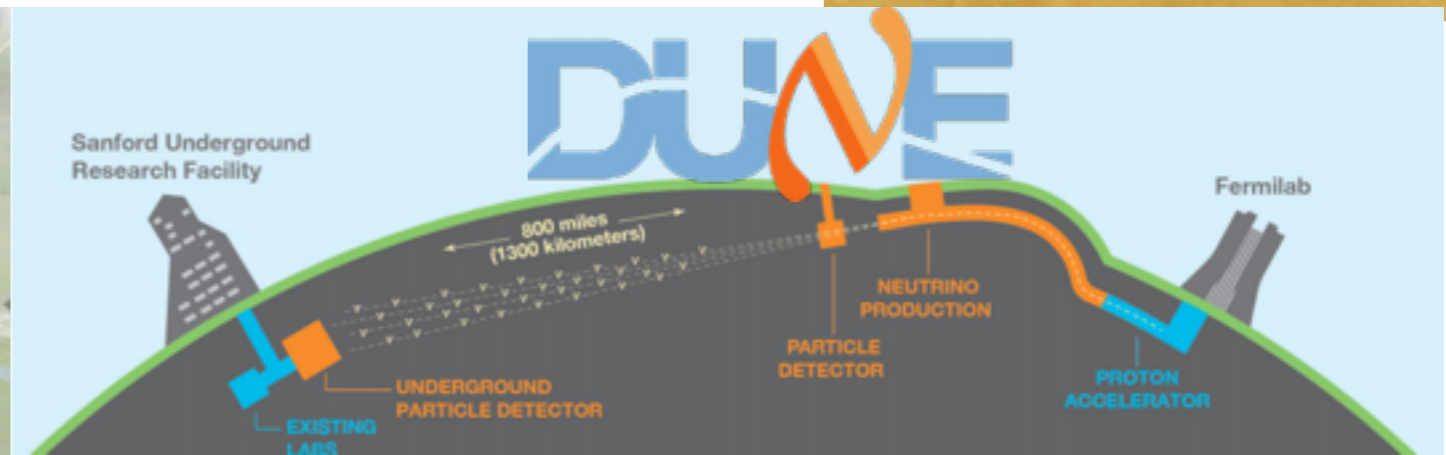
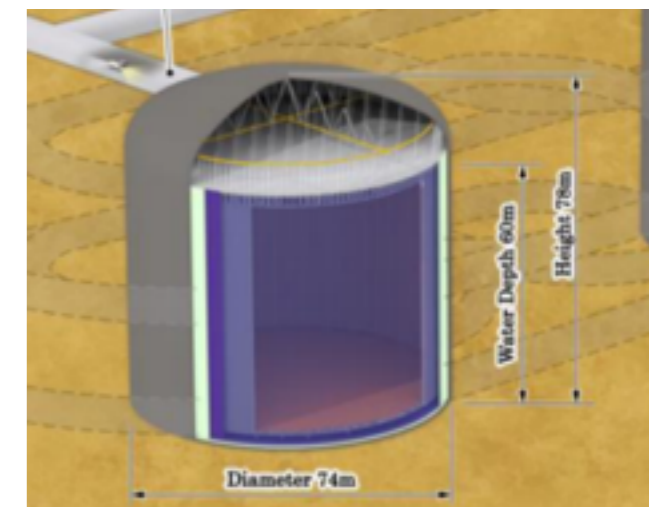
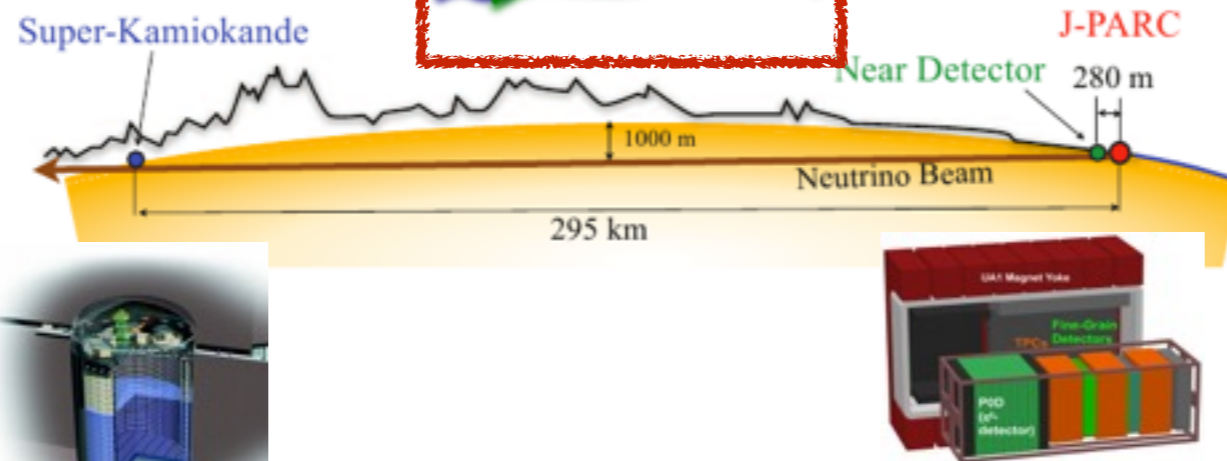
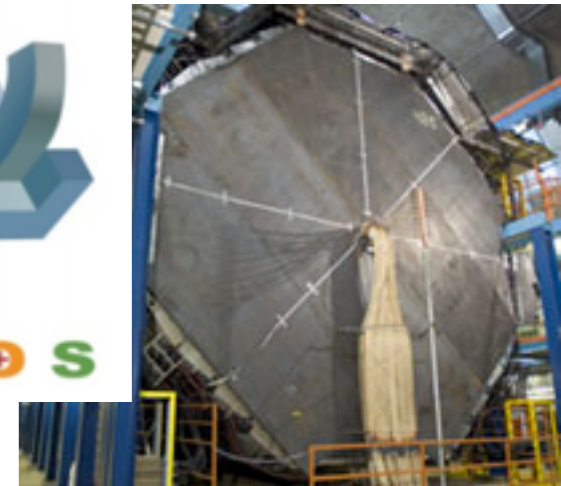
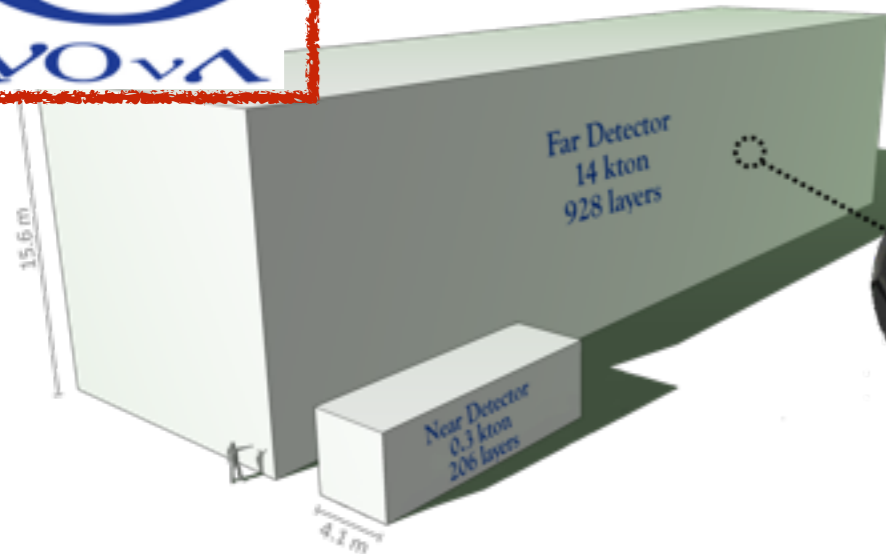

What is measured?

ν_μ disappearance

ν_e appearance

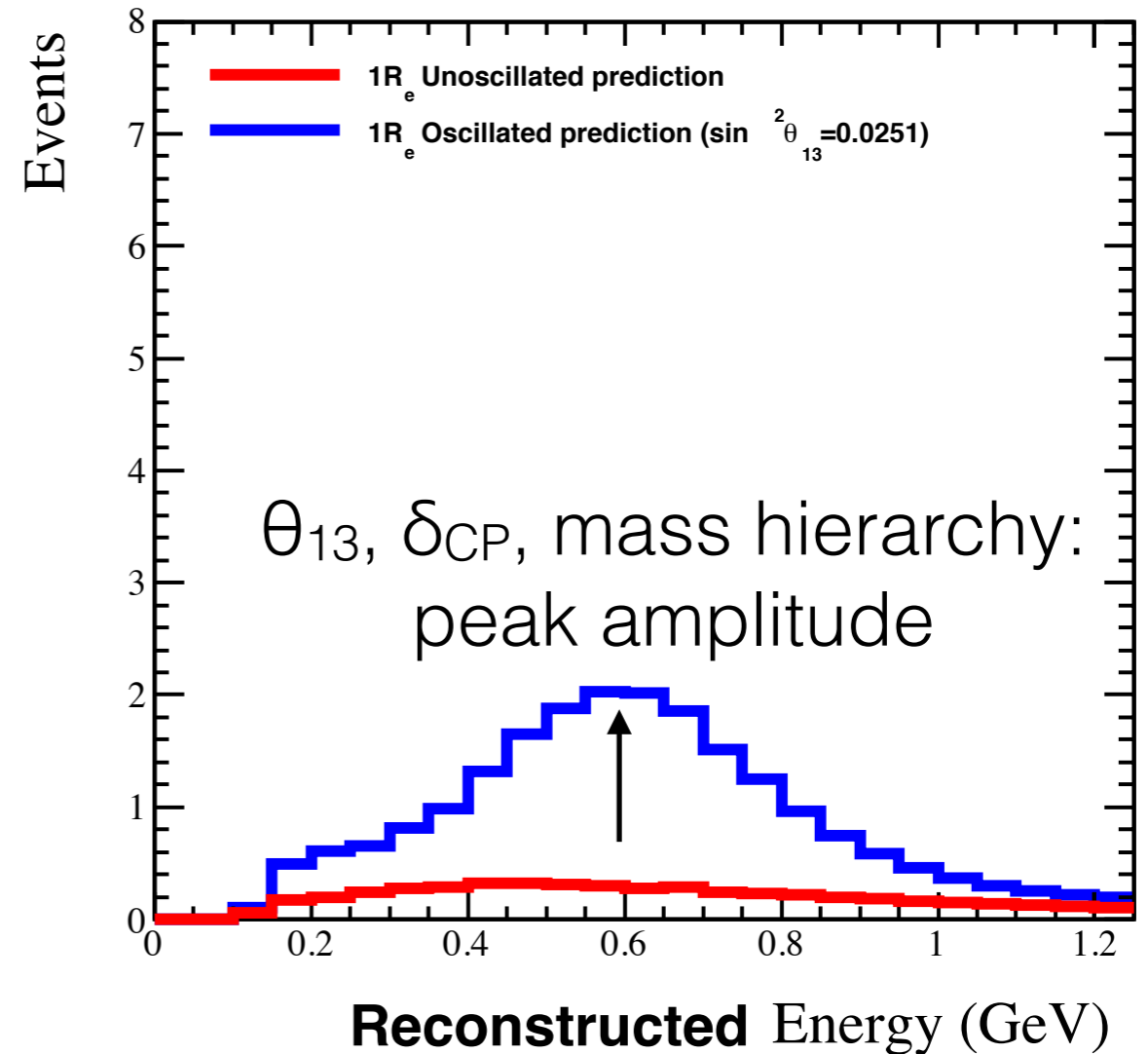
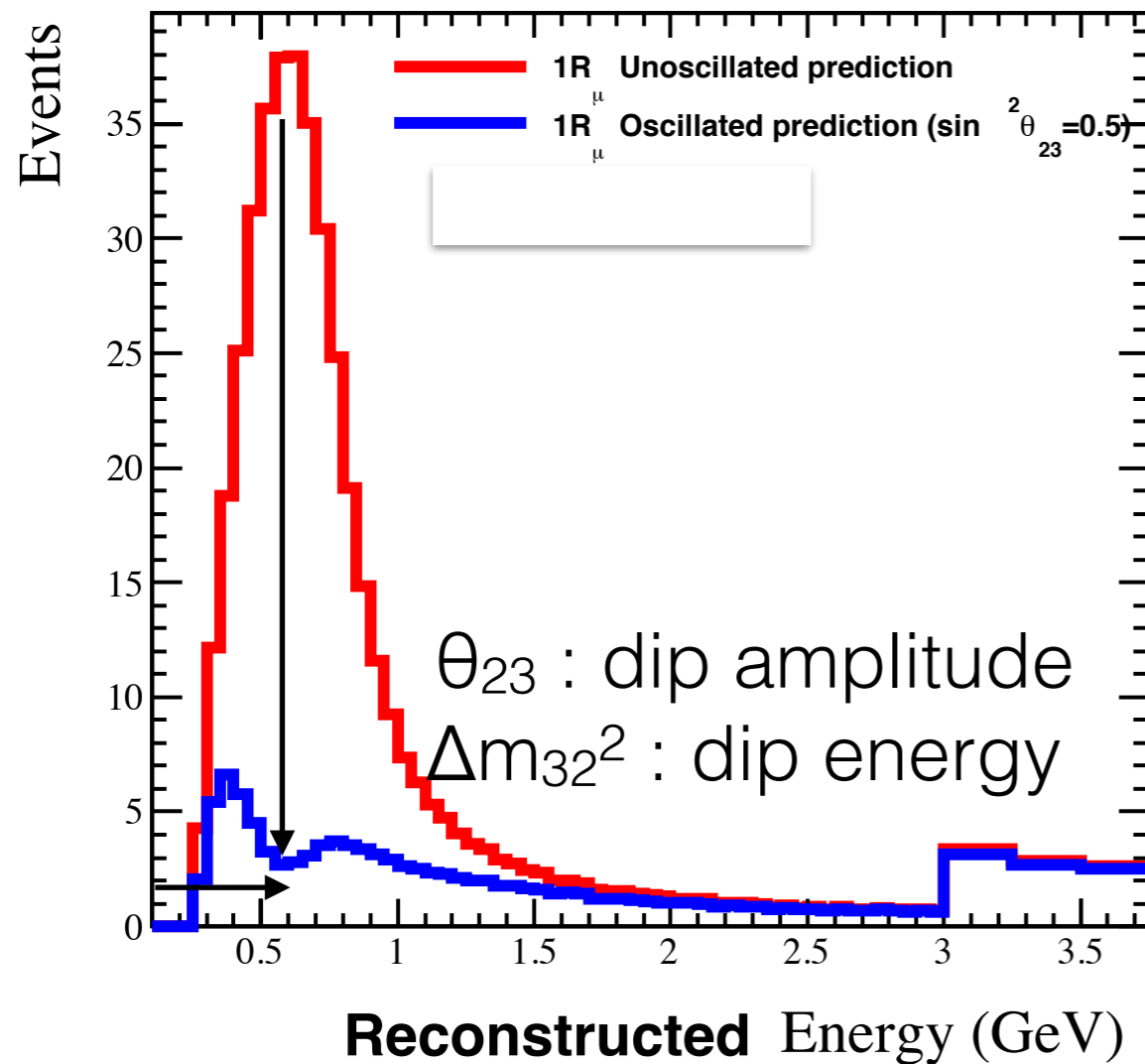

Measurement precision limited by:

- Statistics
- Neutrino energy reconstruction
- Knowledge of unoscillated spectrum and background contamination

Statistics

Experiment	$\nu_e + \bar{\nu}_e$	$1/\sqrt{N}$	Ref.
T2K (current)	74 + 7	12% + 40%	2.2×10 ²¹ POT
NOvA (current)	33	17%	FERMILAB-PUB-17-065-ND
NOvA (projected)	110 + 50	10% + 14%	arXiv:1409.7469 [hep-ex]
T2K-I (projected)	150 + 50	8% + 14%	7.8×10 ²¹ POT, arXiv:1409.7469 [hep-ex]
T2K-II	470 + 130	5% + 9%	20×10 ²¹ POT, arXiv1607.08004 [hep-ex]
Hyper-K	2900 + 2700	2% + 2%	10 yrs 2-tank staged KEK Preprint 2016-21
DUNE	1200 + 350	3% + 5%	3.5+3.5 yrs x 40kt @ 1.07 MW arXiv:1512.06148 [physics.ins-det]

Current appearance measurements stats dominate

$O(10^3) \nu_e$ at future experiments → demands ~2% systematics

$O(10^4) \nu_\mu$ → need systematics as good as we can get!

T2K

 Far Detector
(Super-K)

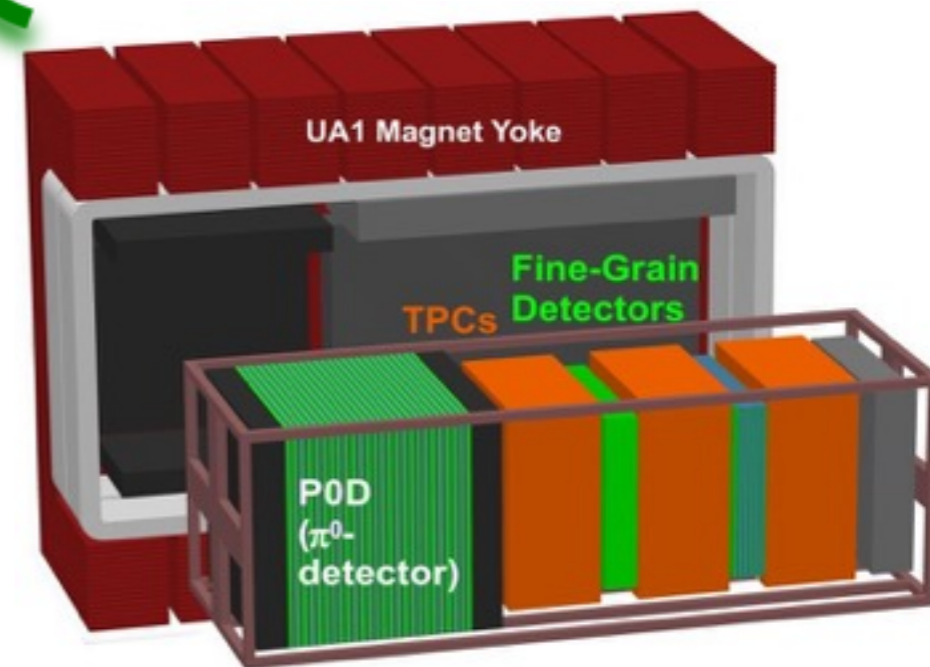

Near Detectors
(ND280+INGRID)

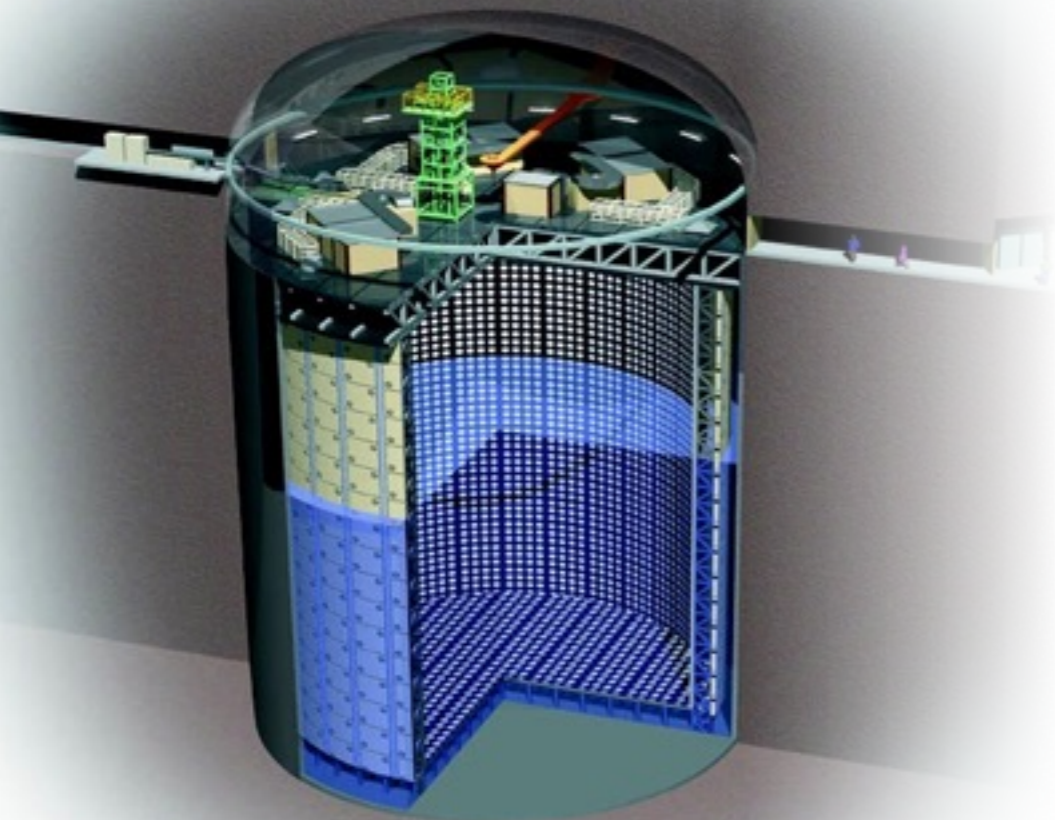
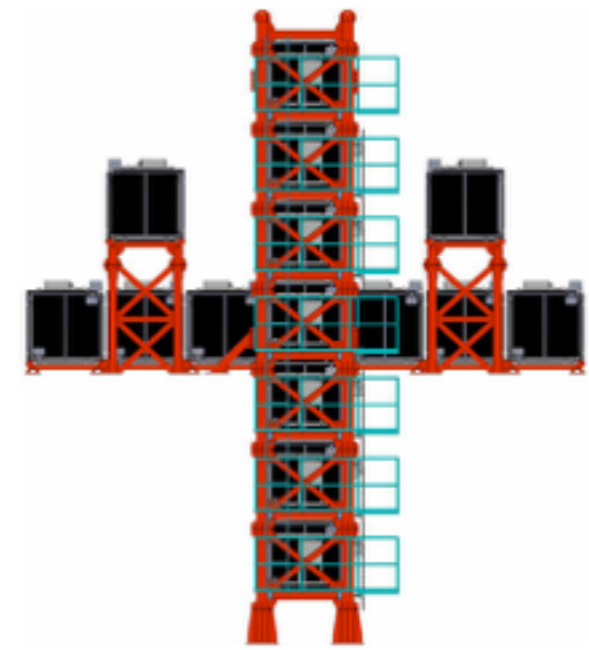



Water Cherenkov Far Detector
>22.5 kt fiducial mass

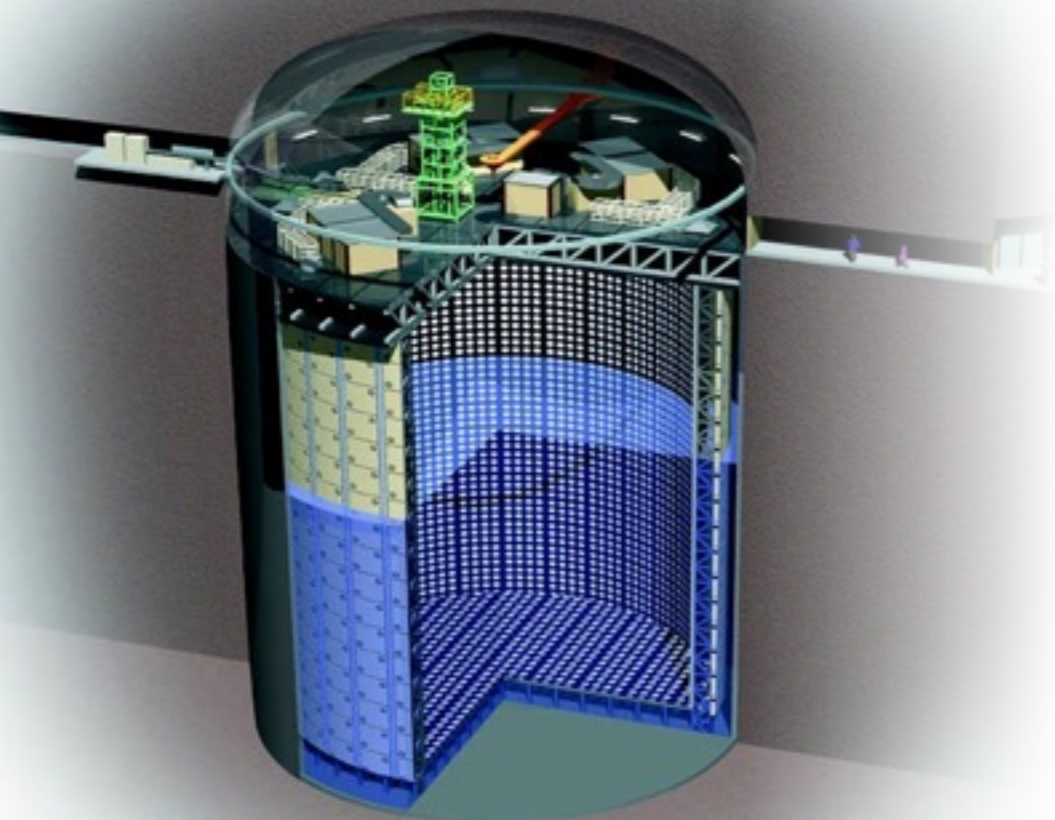

T2K

WARWICK
THE UNIVERSITY OF WARWICK

Muon

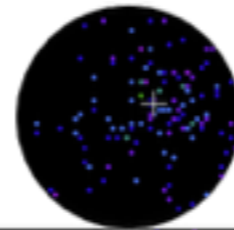

Electron

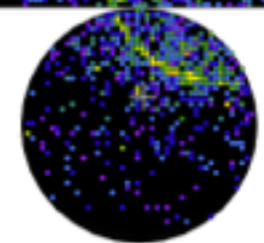
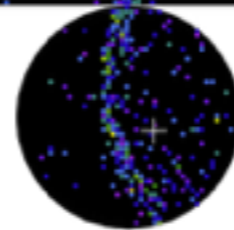
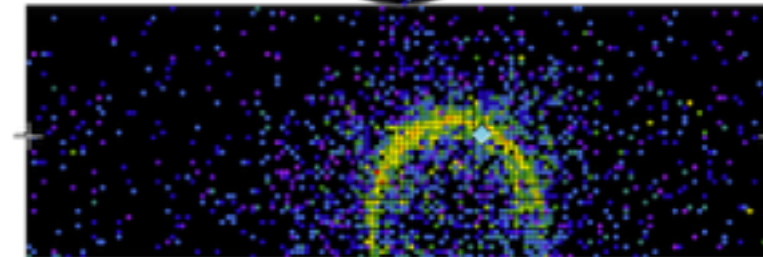
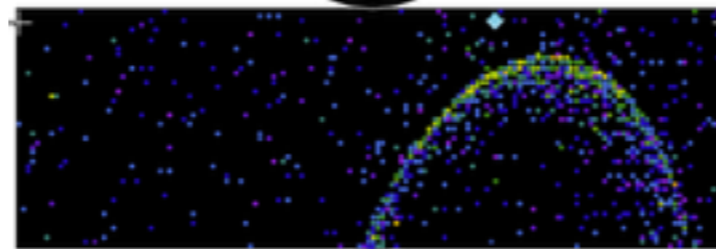
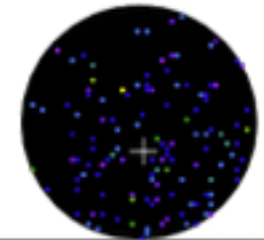

Oxygen target
 4π acceptance

Energy reconstruction from lepton kinematics

Blind to particles below Cherenkov threshold
for protons < 1.1 GeV/c.

(neutron counting possible with SK-Gd)

T2K

Carbon and Oxygen target materials

Acceptance differs from far detector

Magnetic field for sign selection

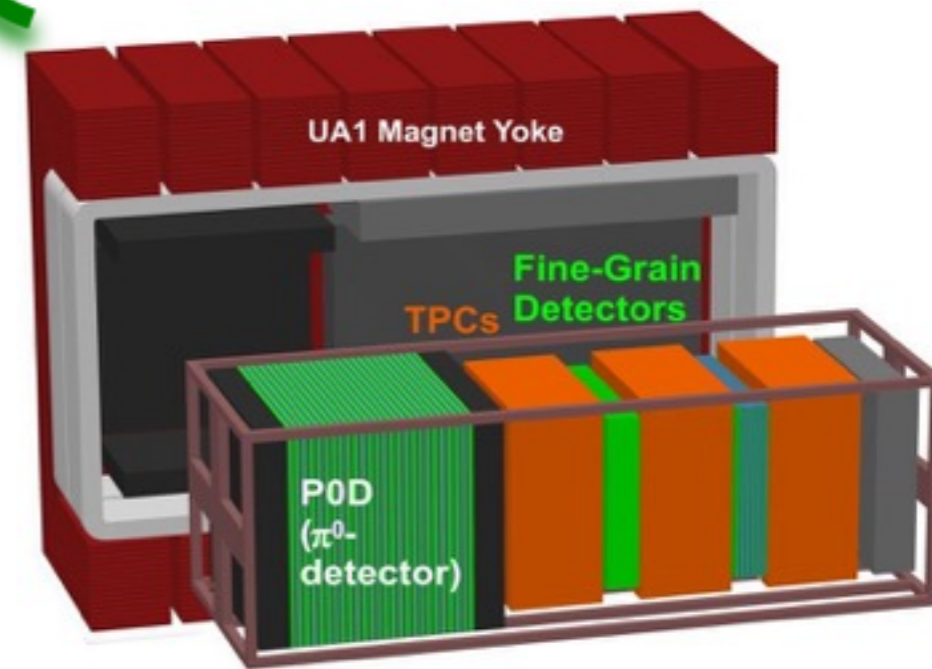

Near Detector (ND280)

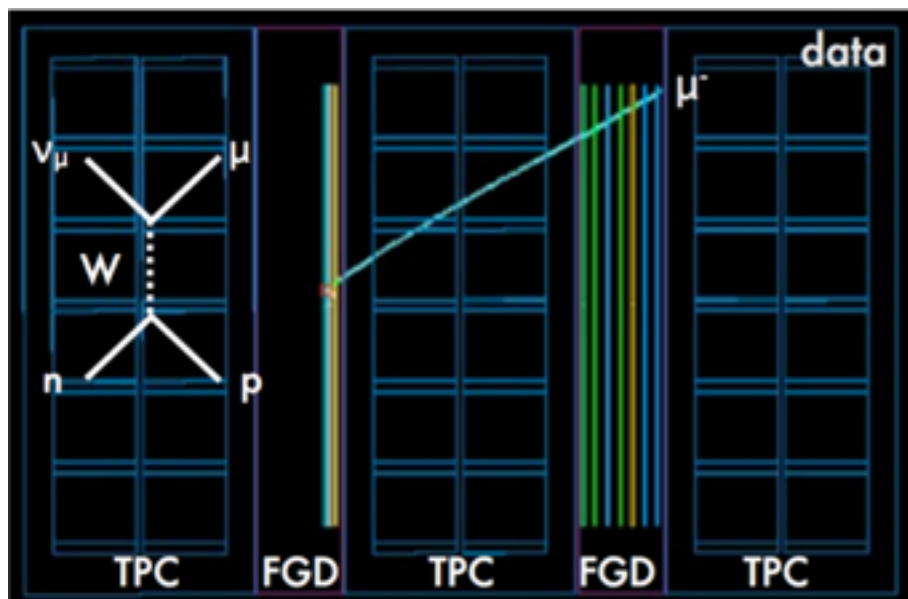

CC $1\mu + 0\pi + X$

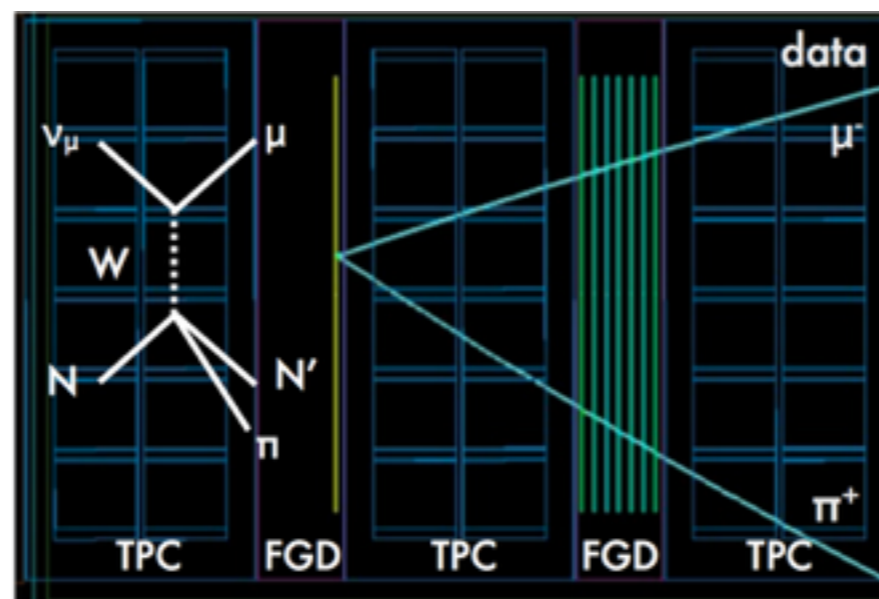

CC $1\mu + 1\pi^+ + X$

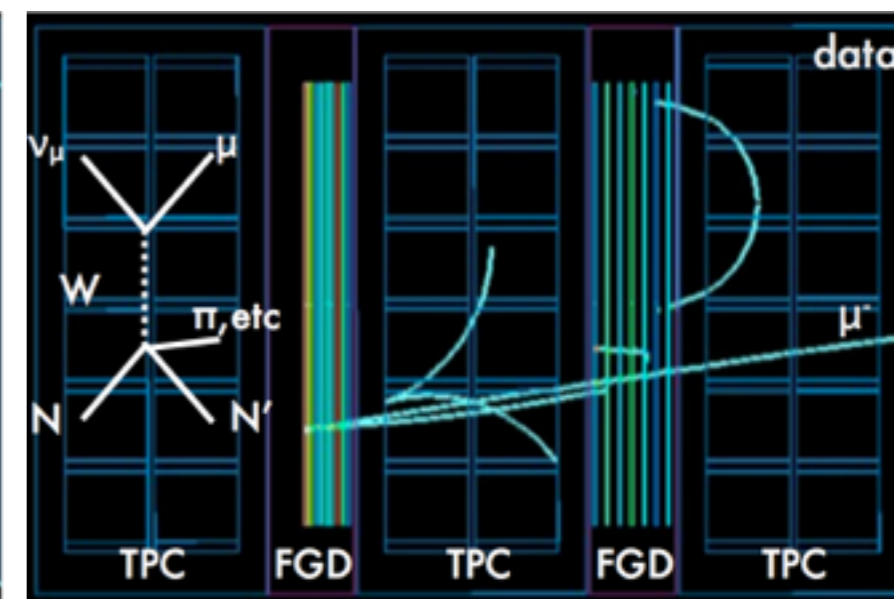

CC other

T2K Analysis Strategy

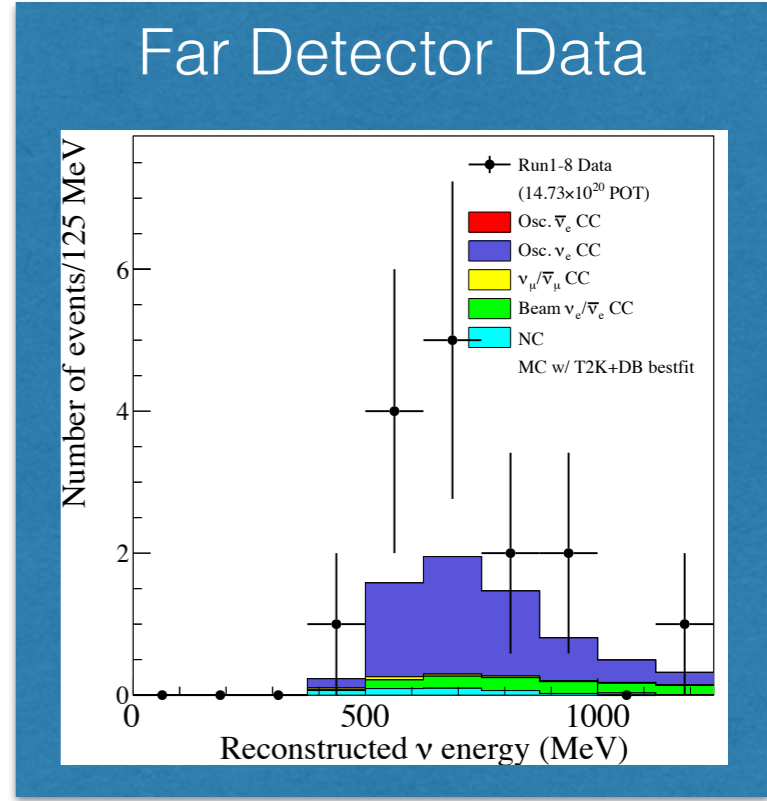
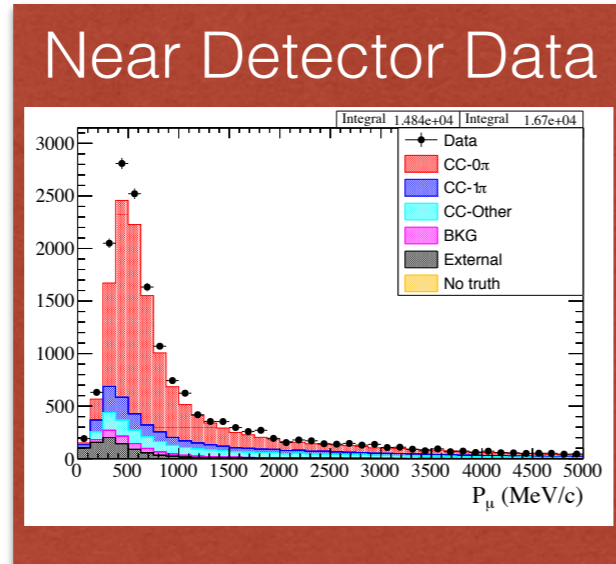

Theoretical Predictions

External Cross Section Measurements

ν -Nucleus Interaction Model

Updated Flux + ν -Nucleus Interaction Model

NA61/SHINE

INGRID and Beam Monitors

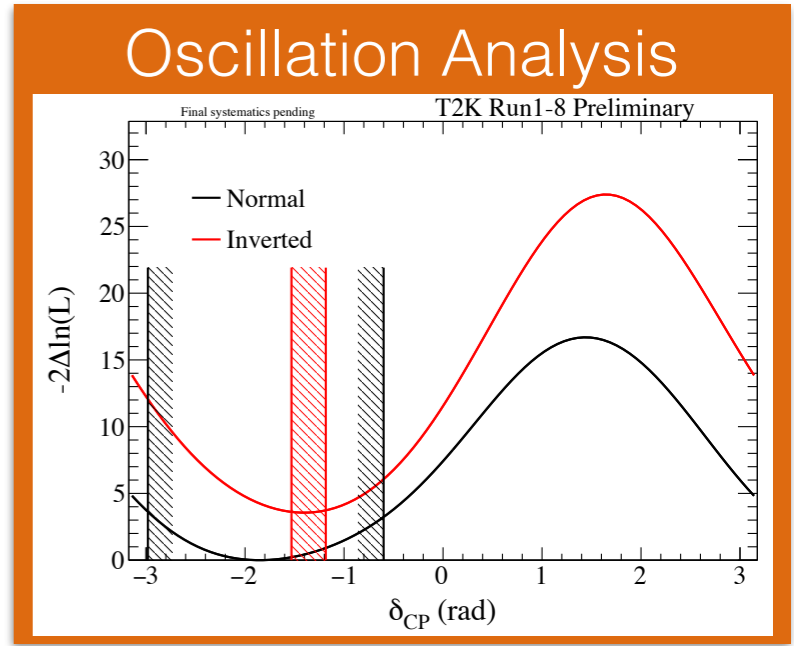
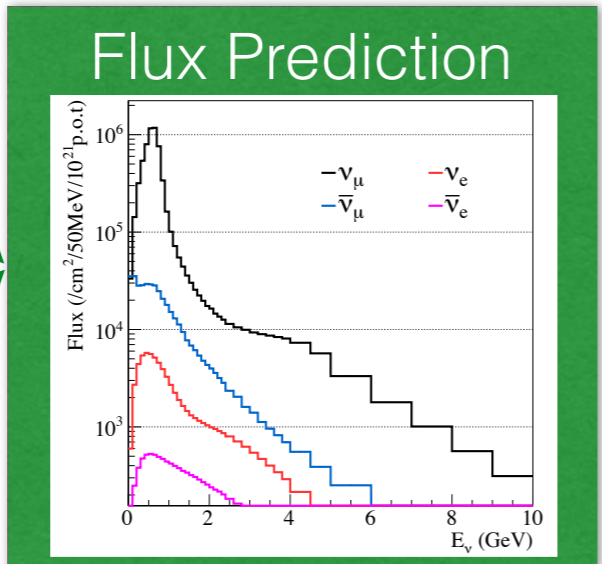

T2K Analysis Strategy

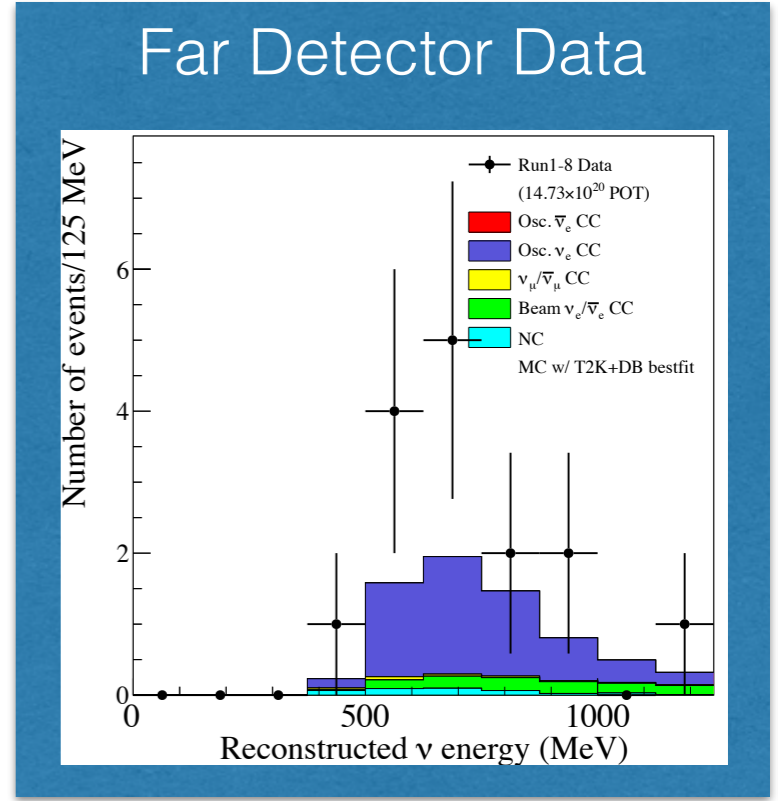
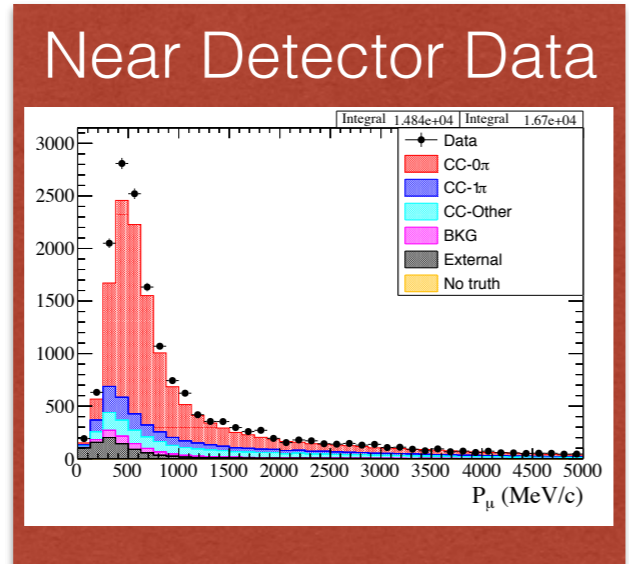

Theoretical Predictions

External Cross Section Measurements

ν -Nucleus Interaction Model

Updated Flux + ν -Nucleus Interaction Model

NA61/SHINE

INGRID and Beam Monitors

Flux Prediction

See talk by P Dunne in next WG1 session for more detail

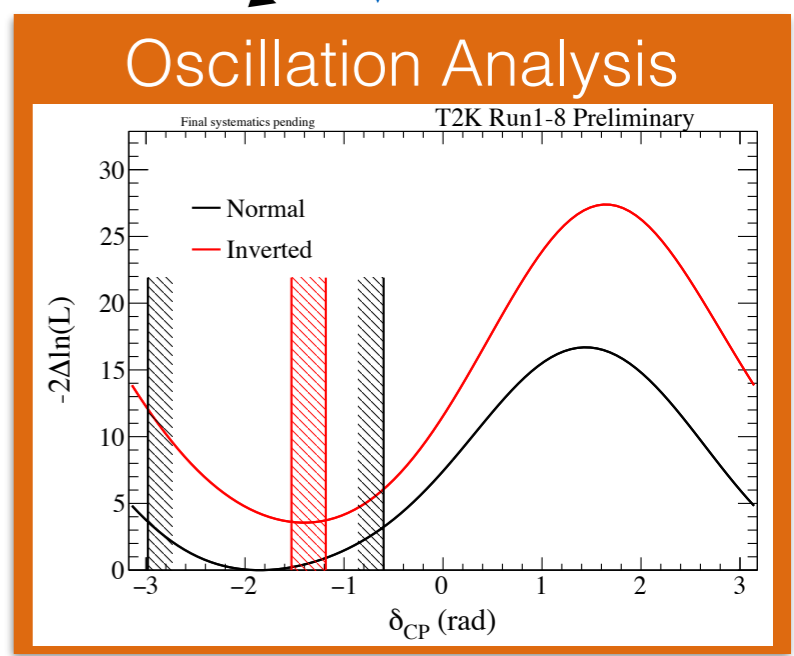

NOvA Experiment

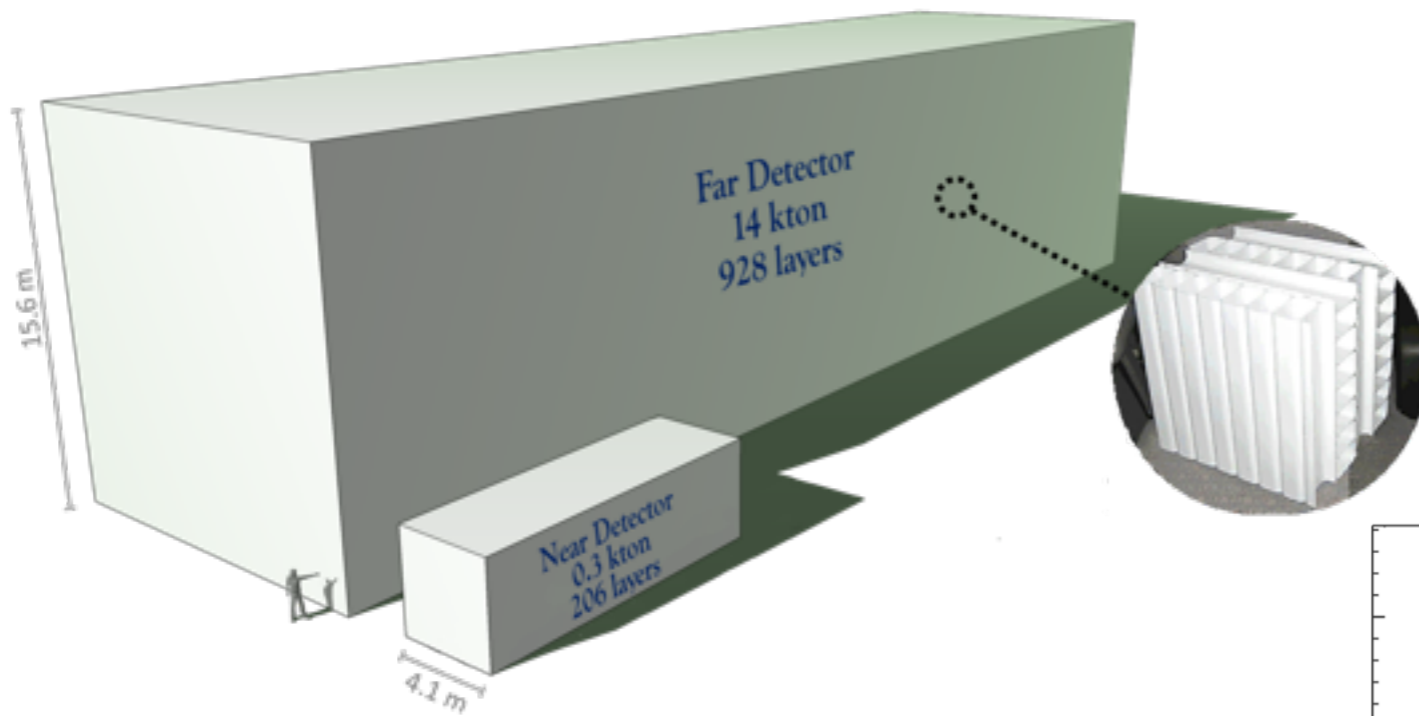

Liquid Scintillator tracking calorimeter

Almost identical near far detectors

Calorimetric Energy Reconstruction

$$E_{\nu \text{ reco}} = E_{\text{lep}} + E_{\text{had}}$$

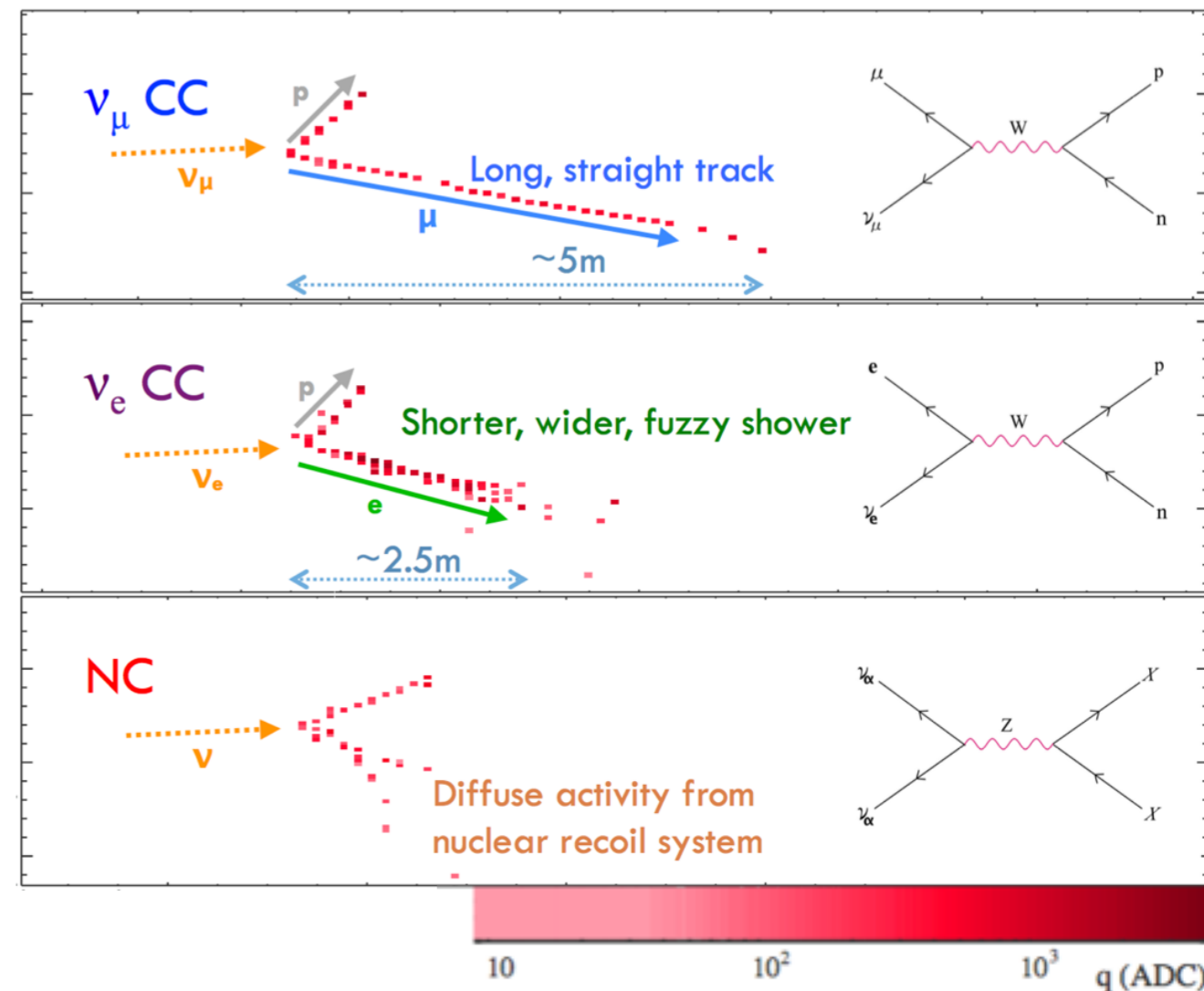

NOvA Analysis Strategy

To produce a data-driven prediction at FD, based on ND:

J. Wolcot, NuInt 2017

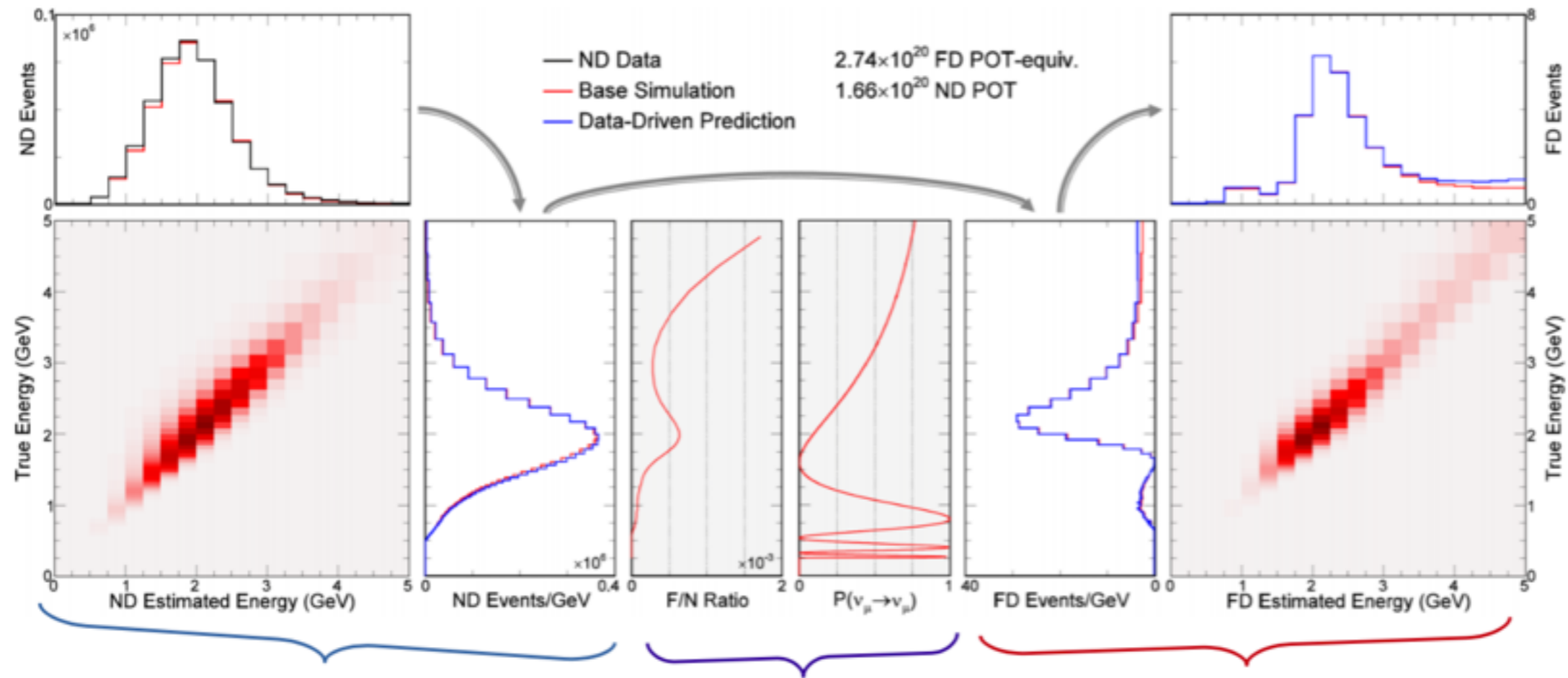

True energy distribution is corrected so that reconstructed data & MC agree at the ND...

...modified true energy distribution is propagated through predicted geometric beam dispersion & acceptance ratio, oscillations...

... and "extrapolated" reconstructed energy distribution computed to compare to data

NOvA Analysis Strategy

To produce a data-driven prediction at FD, based on ND:

J. Wolcot, NuInt 2017

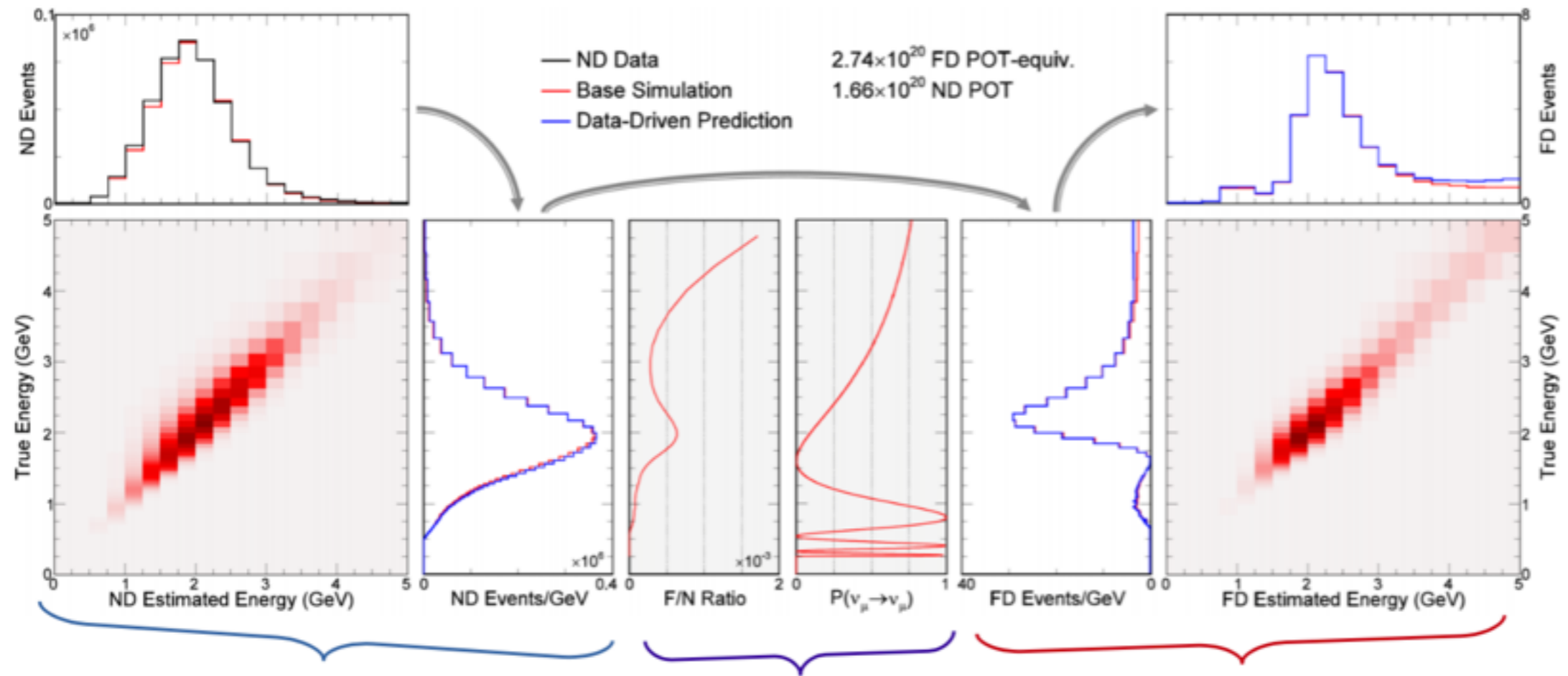

True energy distribution is corrected so that reconstructed data & MC agree at the ND...

...modified true energy distribution is propagated through geometric beam acceptance ratios

See talk by L Cremonesi in next WG1 session for more details

Flux Uncertainties

SK: Neutrino Mode, ν_μ

T2K

Fractional Error

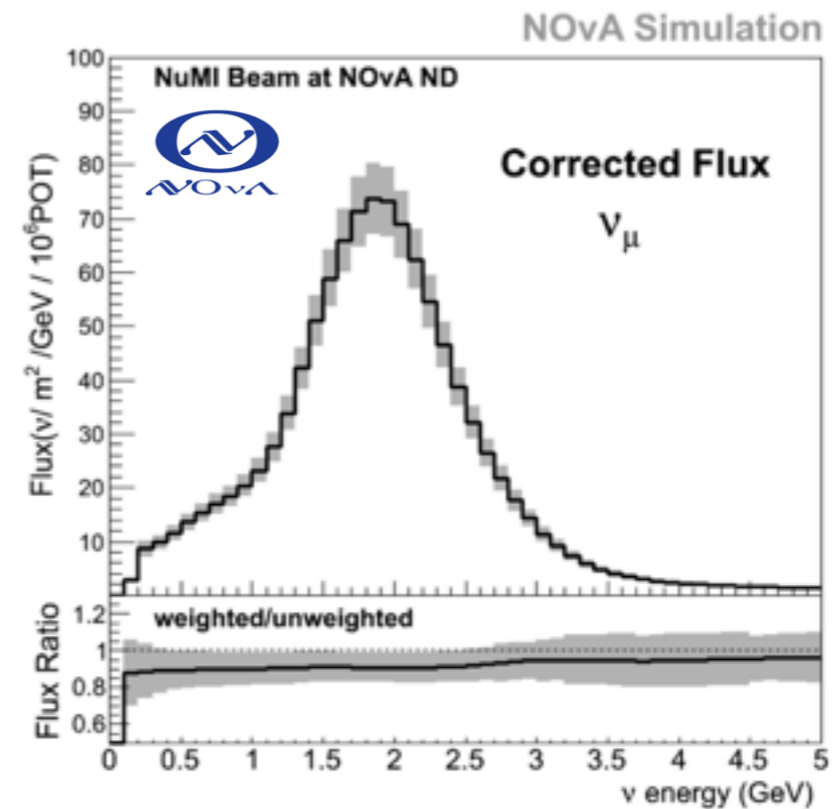
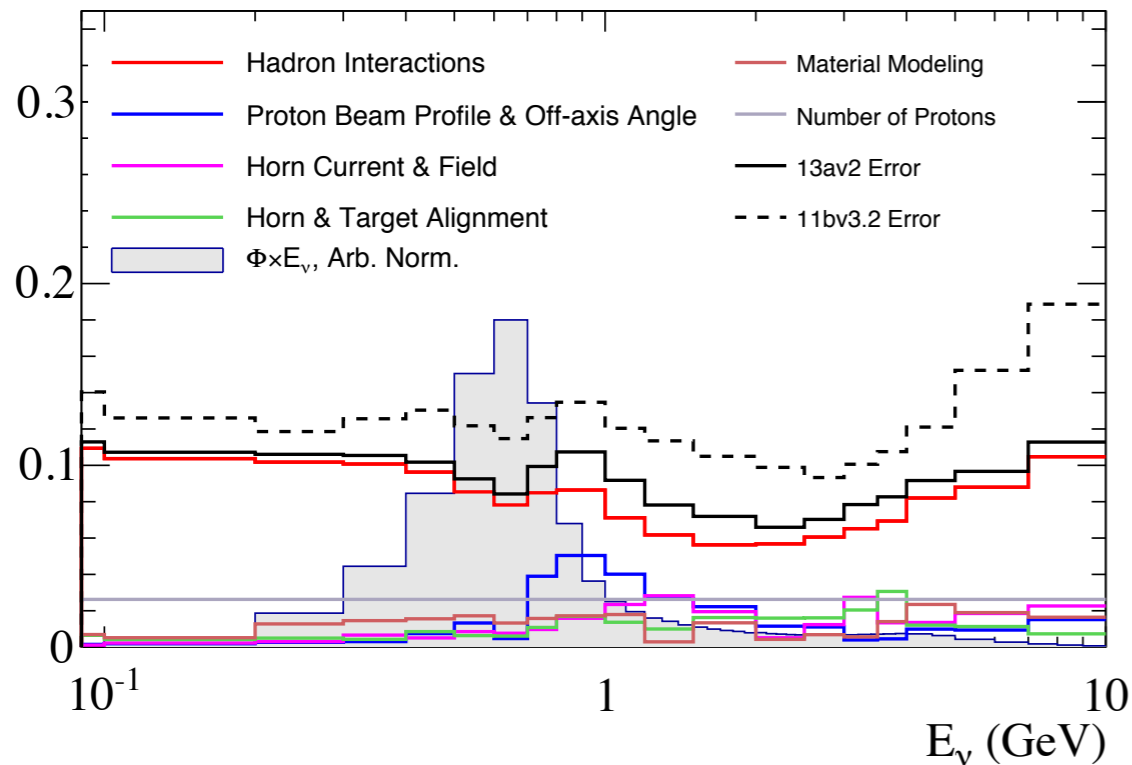

T2K \sim 8-12% (based on thin target tuning)

Dominated by hadron interaction modelling

Alignment/focussing uncertainties are also important
(especially for near to far extrapolation)

Flux Uncertainties

Thin Target \longrightarrow Thick Target

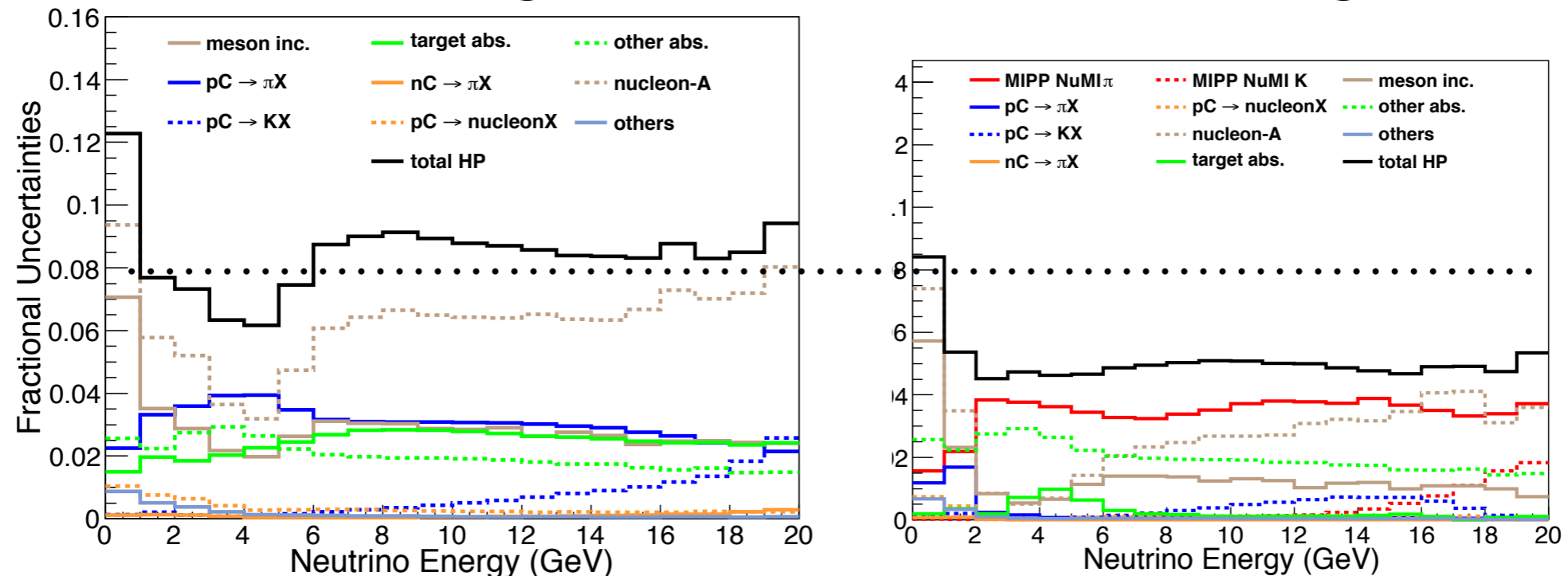

MINERvA Low E NuMI Flux Uncertainties, Phys. Rev. D 95, 039903 (2017)

Significant reductions from thick/replica target

Future high beam power experiments may have different target material/geometry requiring dedicated hadron production measurements

Neutrino Interaction Model Uncertainties

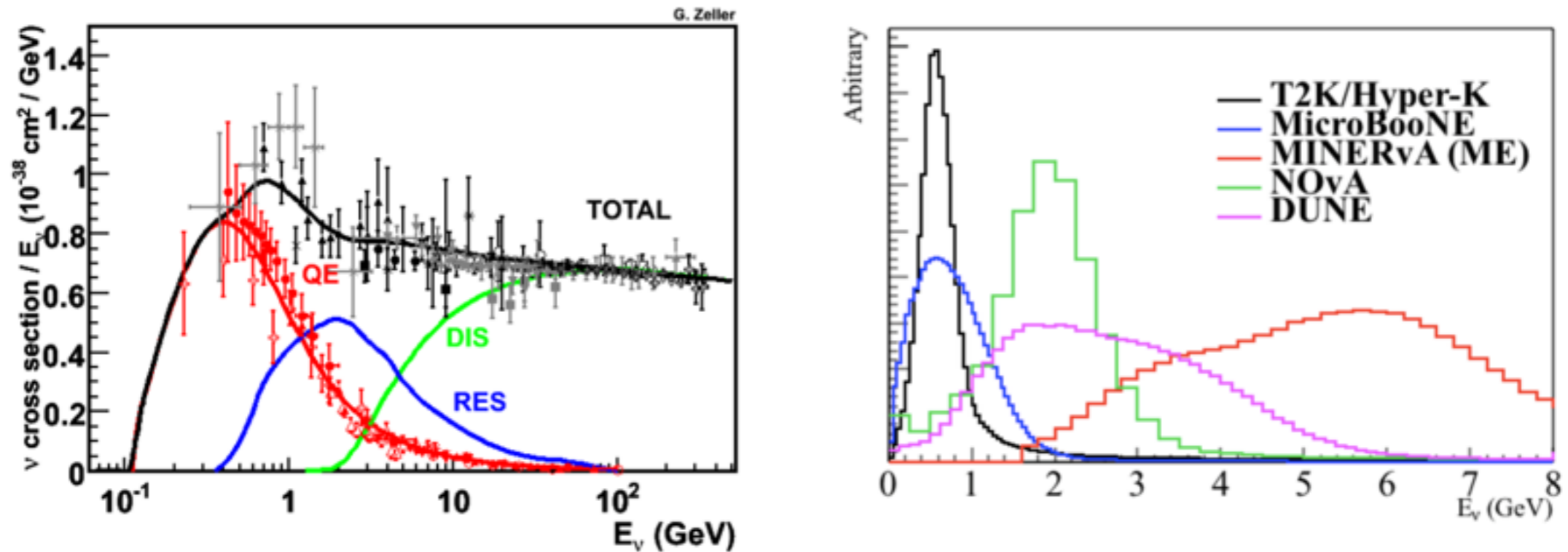

Wide range of processes need to be simulated
Require both lepton and hadronic side of the interaction
Nuclear effects important in the relevant energy regime

Experiments rely on MC generators
for $E_{\text{visible}} \rightarrow E_\nu$ extrapolation

Model parameter uncertainties from fits to external datasets

Sometimes parameter error must be inflated or ad-hoc parameters to account
for discrepancies between model and data or known flaws in the model

T2K Cross-Section Model

Implemented in NEUT MC generator

Quasi-elastic scattering most important process at T2K energies

- Valencia 2p-2h model Phys. Rev. C83 (2011) 045501
- Long-range effects with Random Phase Approximation
- Parameters introduced to vary normalisation and shape
- Relativistic Fermi Gas (RFG) nuclear model
- Uncertainties from RFG \leftrightarrow Local Fermi Gas
- Final state interactions with cascade model

No priors on most CCQE parameters
Constraint from near detector

Impact of alternative models not implemented in oscillation analysis evaluated with fake data studies

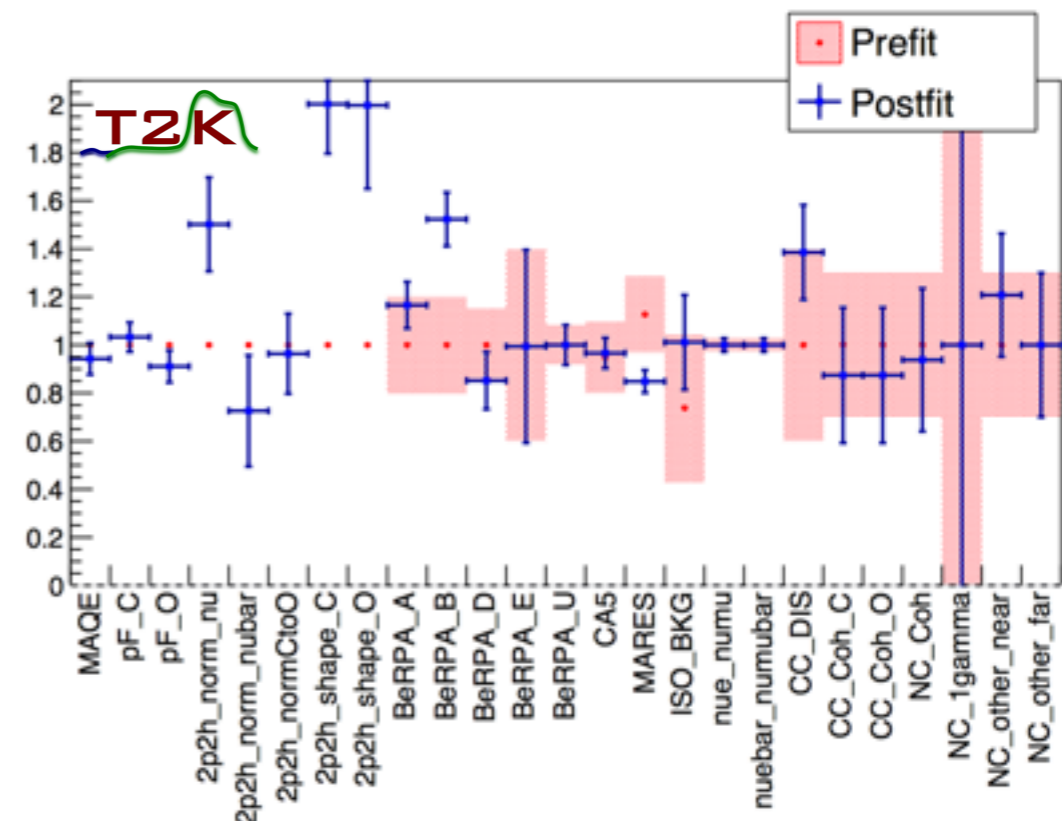
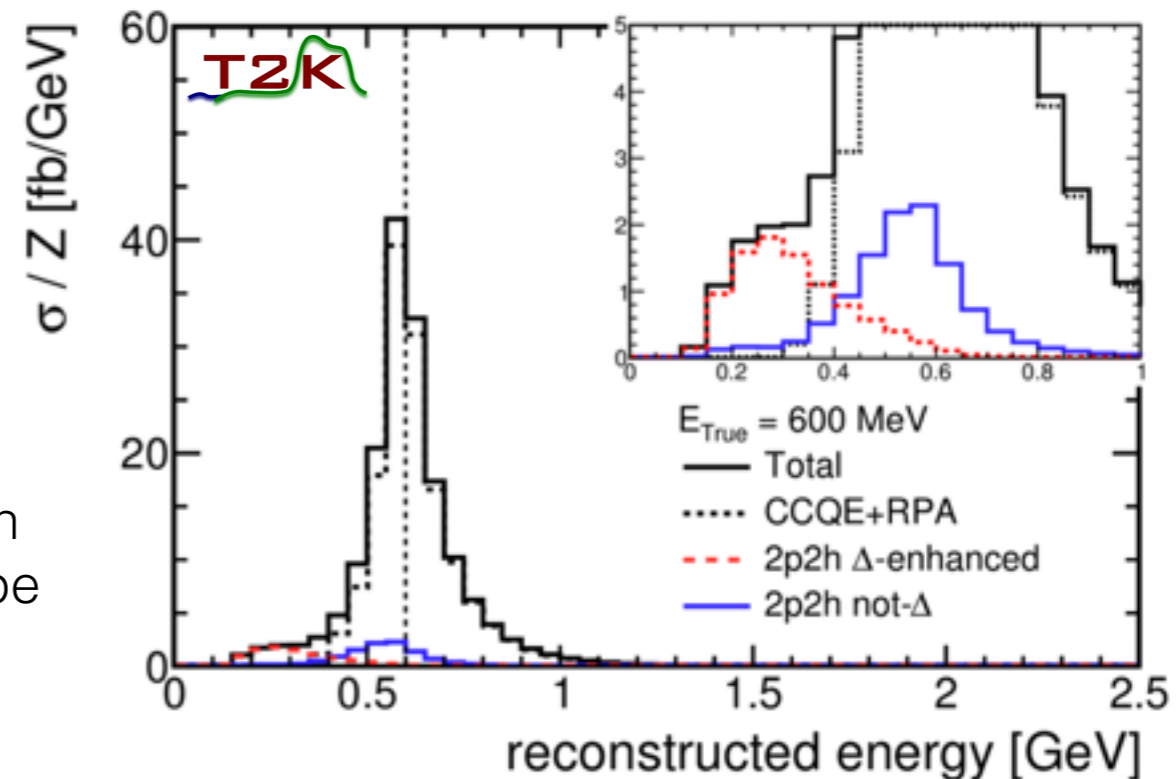

T2K Cross-Section Model

Implemented in NEUT MC generator

Quasi-elastic scattering most important process at T2K energies

- Valencia 2p-2h model Phys. Rev. C83 (2011) 045501
- Long-range effects with Random Phase Approximation
- Parameters introduced to vary normalisation and shape
- Relativistic Fermi Gas (RFG) nuclear model
- Uncertainties from RFG \leftrightarrow Local Fermi Gas
- Final state interactions with cascade model

No priors on most CCQE parameters
Constraint from near detector

Impact of alternative models not implemented in oscillation analysis evaluated with fake data studies

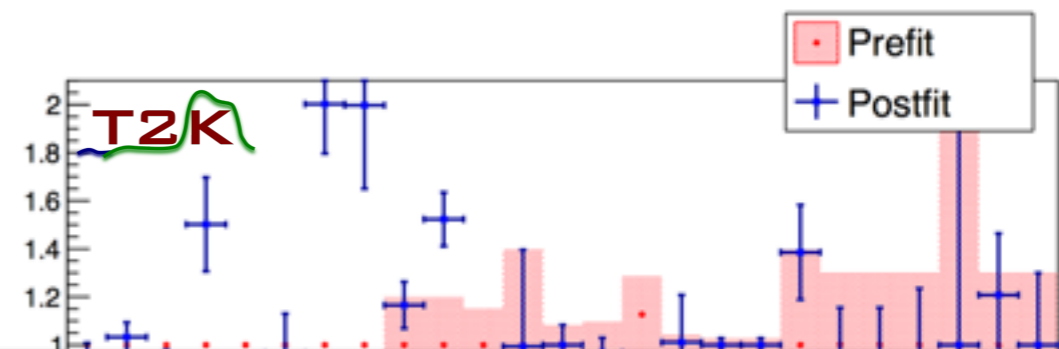
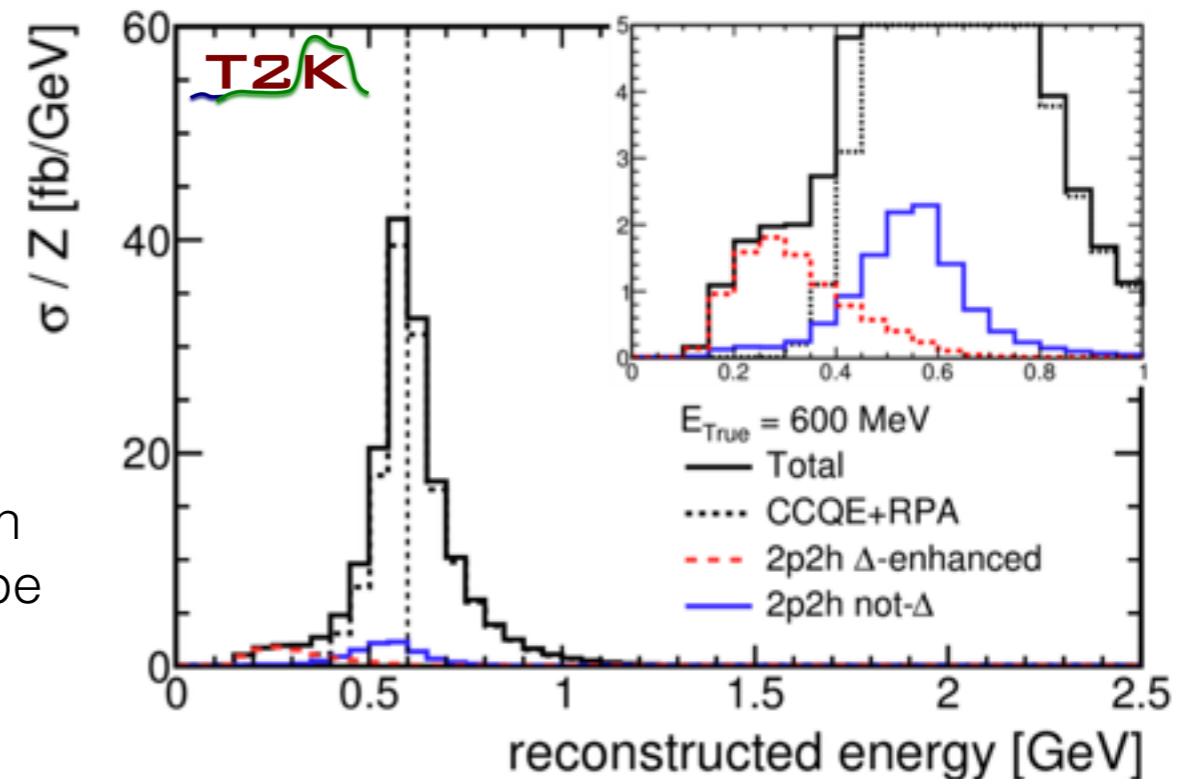

See talk by K Nakamura
in Tuesday WG1+2
session for more details

NOvA Cross-section Model

Use GENIE MC generator and uncertainties

Some additions/modifications

- Empirical 2p2h model, tuned to match ND data
- Parameters to cover RPA uncertainties
- Alternative tuning of CC1 π model [Eur. Phys. J. C 76, 474 (2016)]

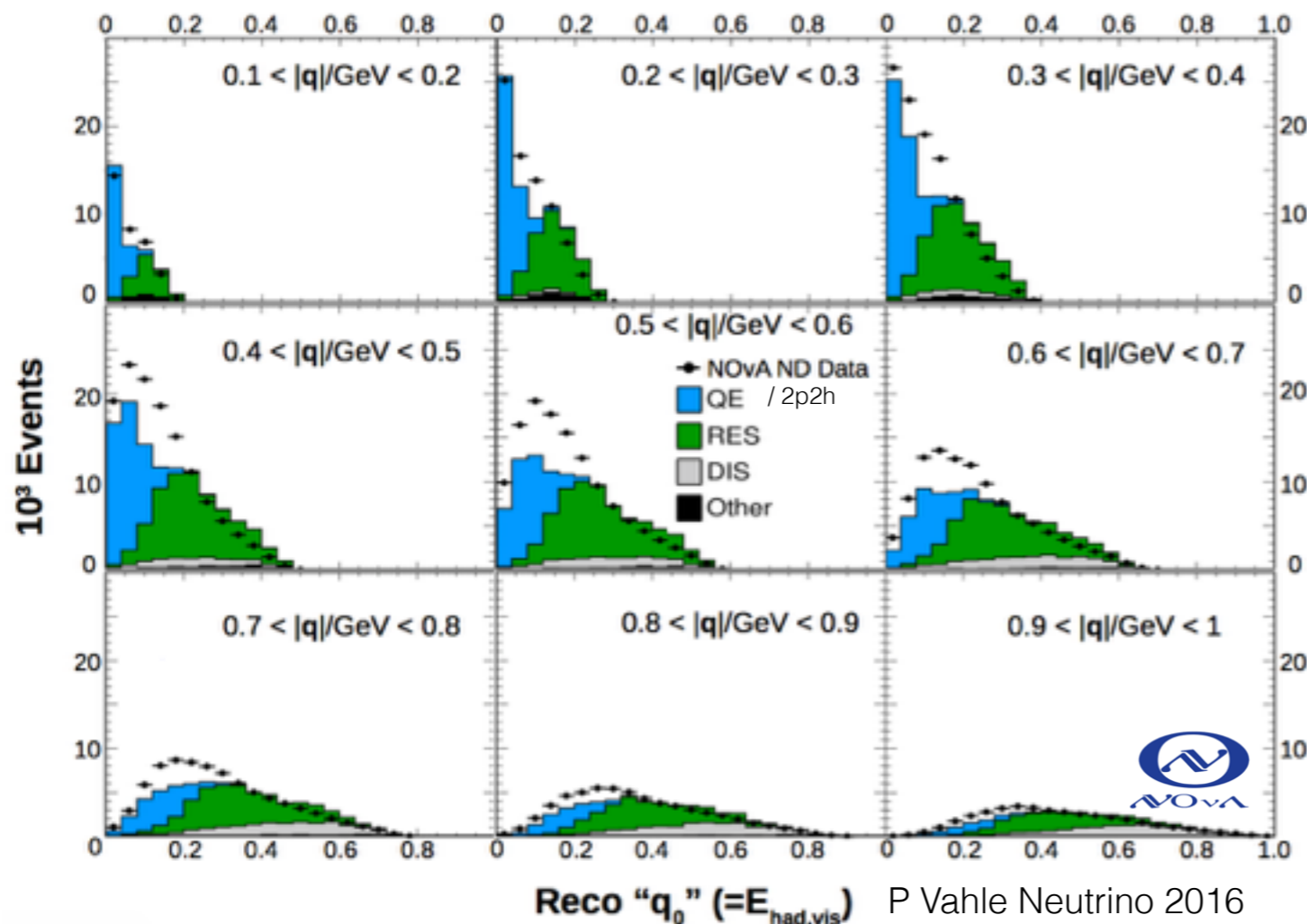

J. Wolcot, NuInt 2017 NOvA Simulation

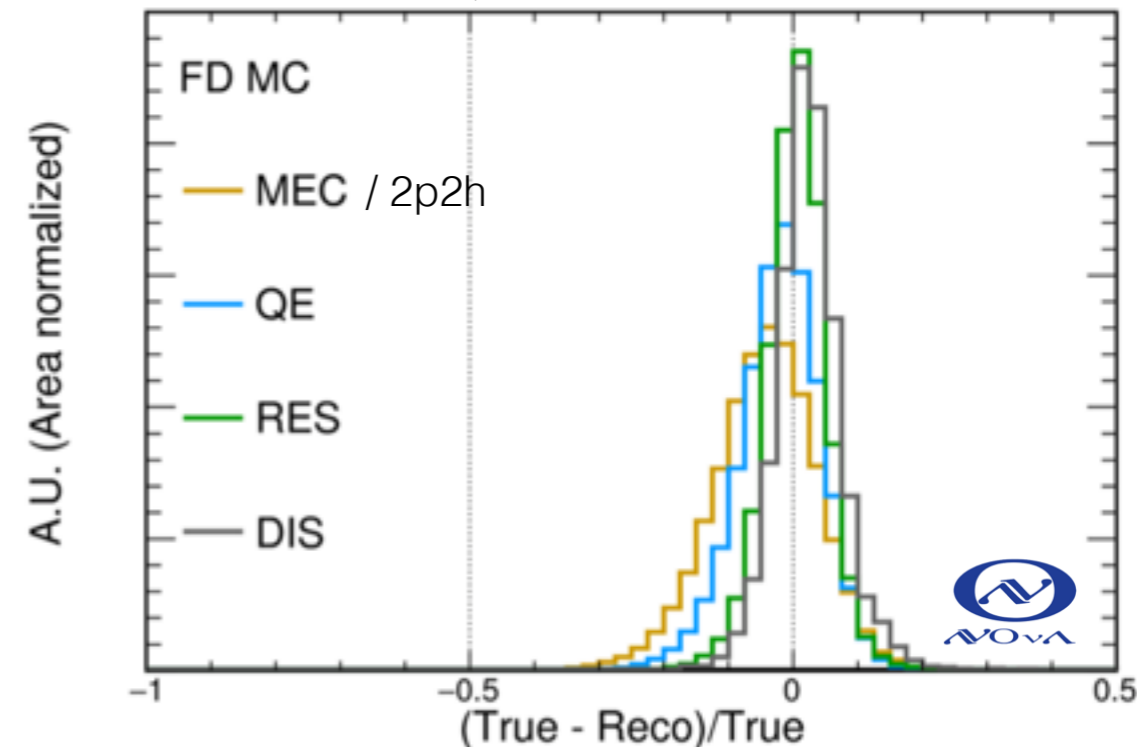

NOvA Simulation

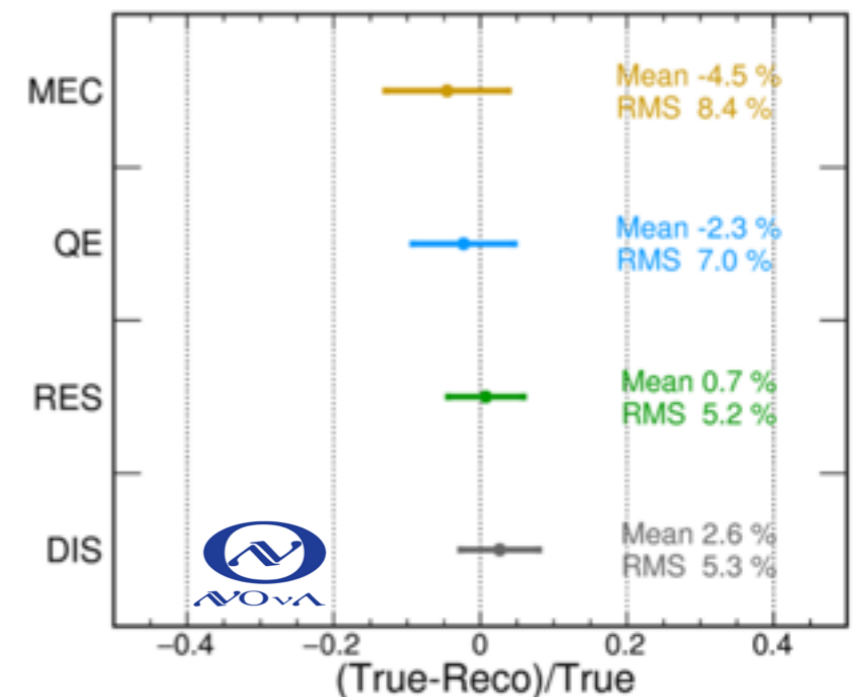

NOvA Cross-section Model

Use GENIE MC generator and uncertainties

Some additions/modifications

- Empirical 2p2h model, tuned to match ND data
- Parameters to cover RPA uncertainties
- Alternative tuning of CC1 π model [Eur. Phys. J. C 76, 474 (2016)]

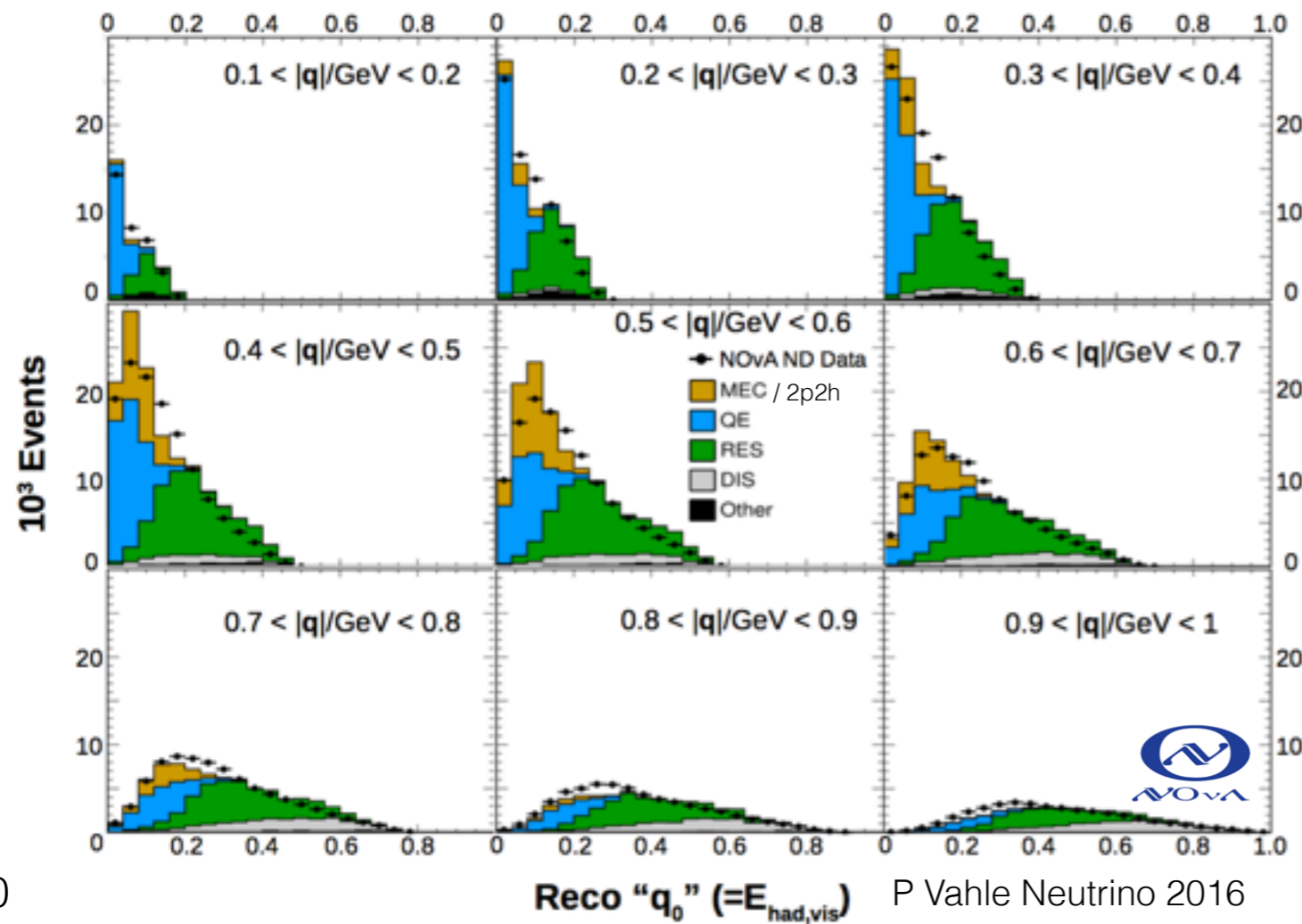

P Vahle Neutrino 2016

J. Wolcot, NuInt 2017 NOvA Simulation

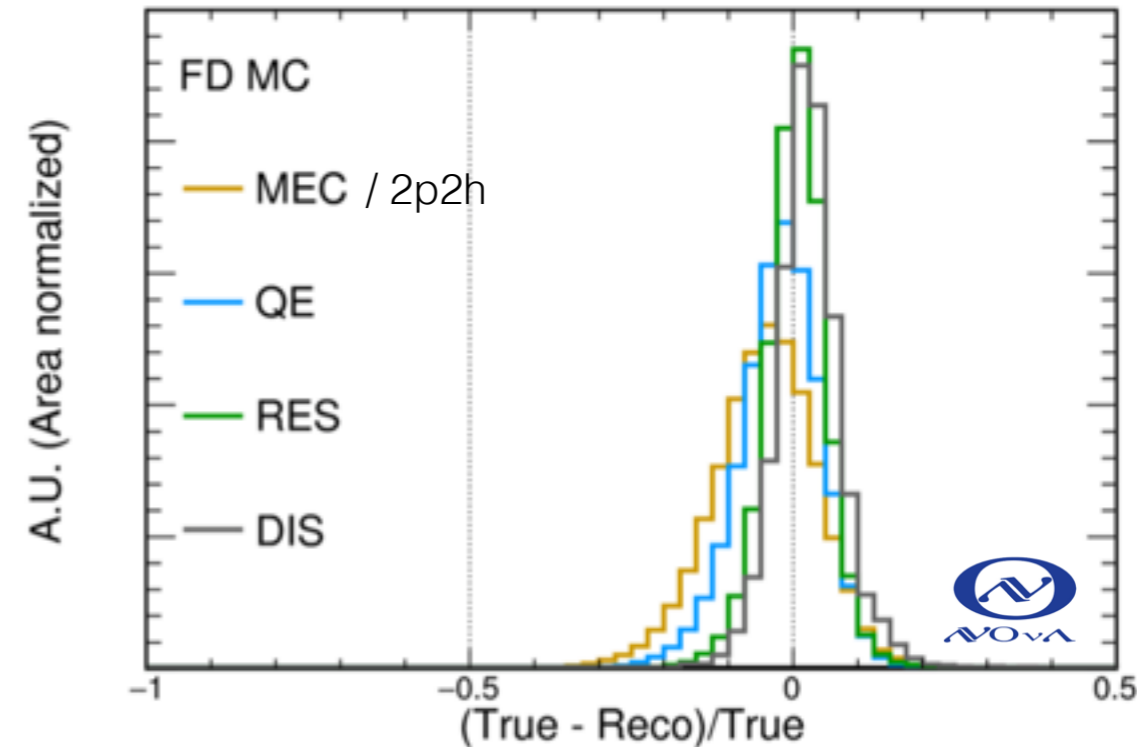

NOvA Simulation

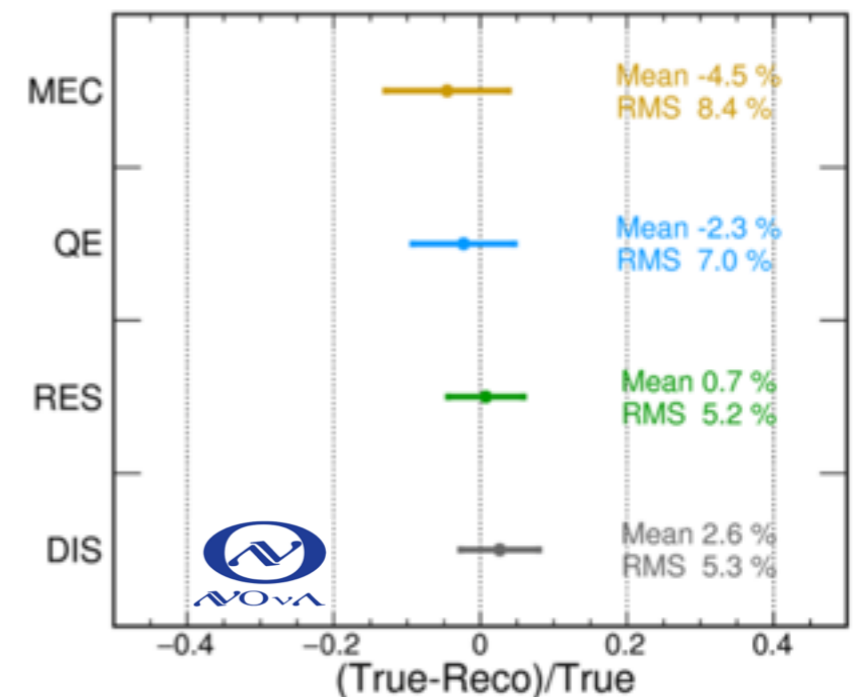

NOvA Cross-section Model

Use GENIE MC generator and uncertainties

Some additions/modifications

- Empirical 2p2h model, tuned to match ND data
- Parameters to cover RPA uncertainties
- Alternative tuning of CC1 π model [Eur. Phys. J. C 76, 474 (2016)]

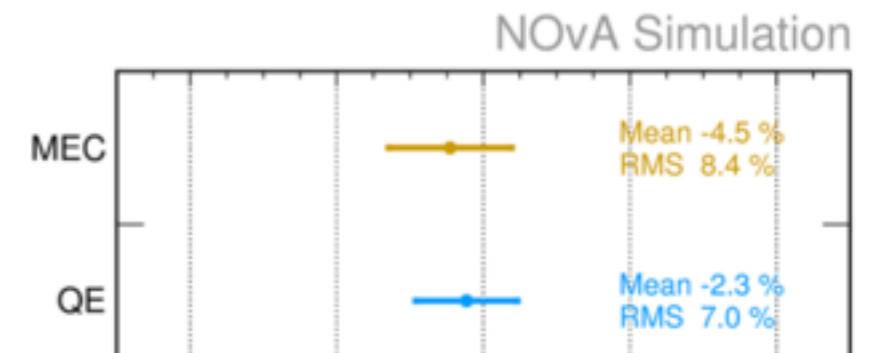
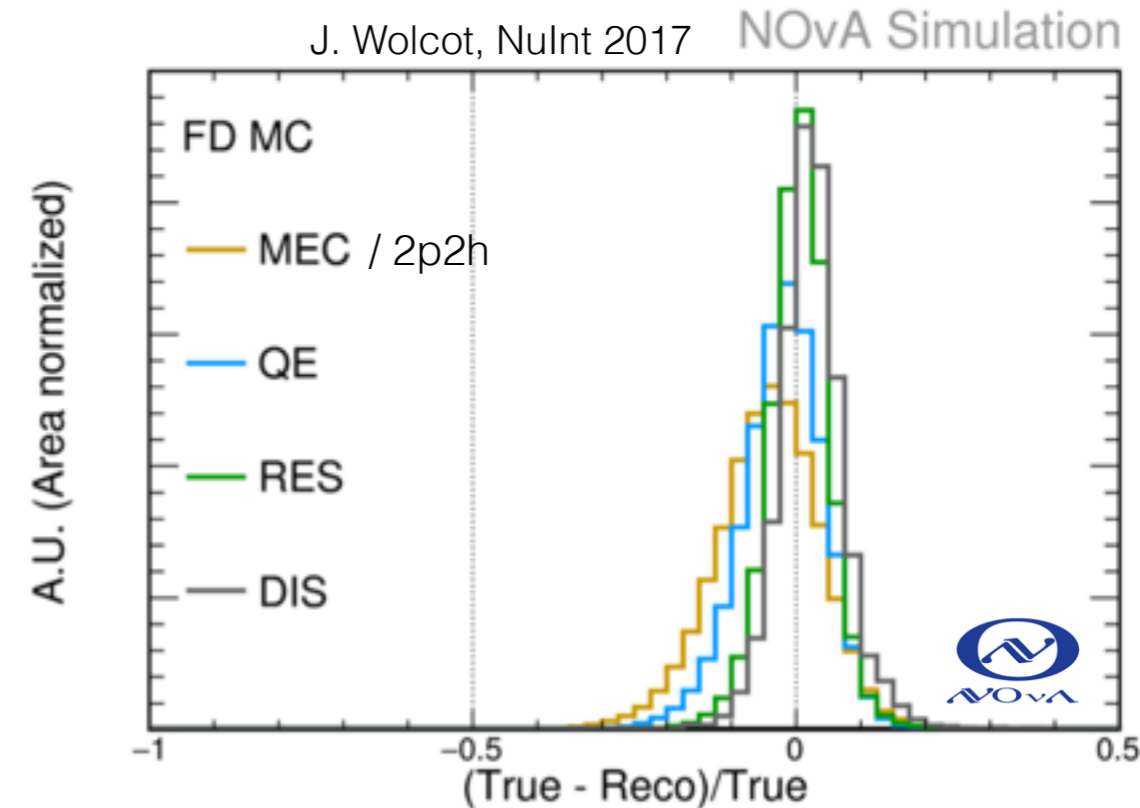
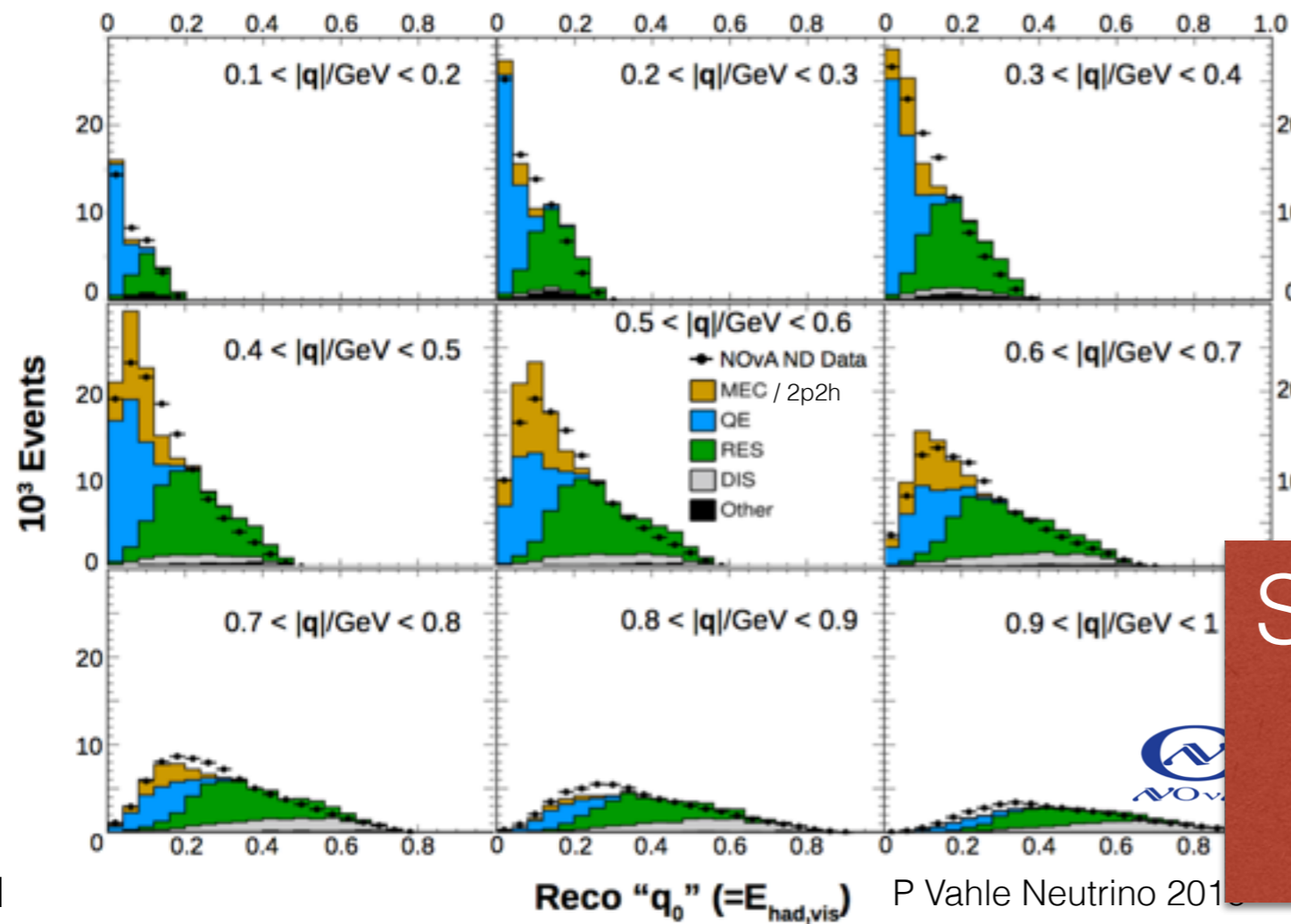

See talk by K Bays talk in WG1+WG2 session for more details

Detector Modelling Uncertainties

SK detector response evaluated with atmospheric sample

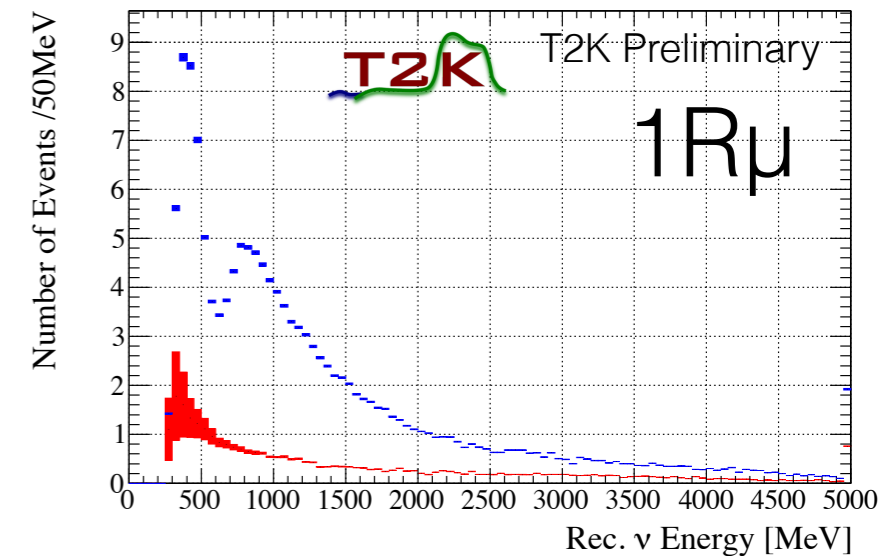
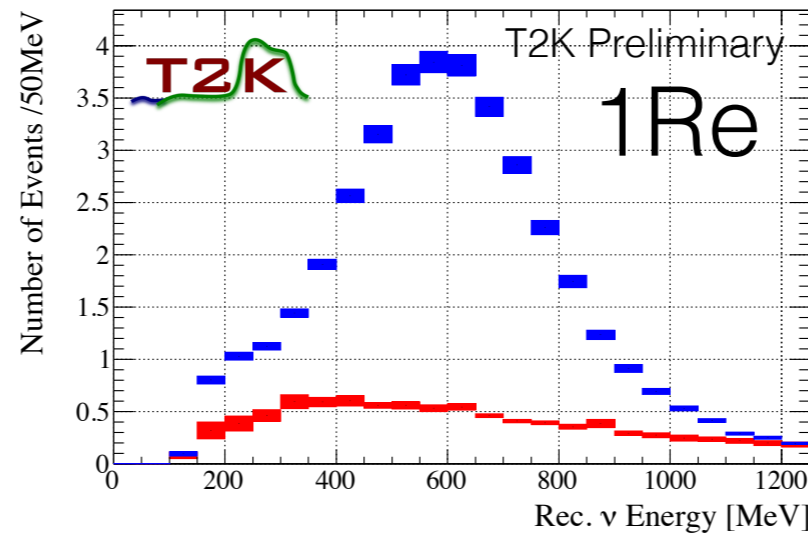

NOvA detector response evaluated with beam and cosmic muon samples in both ND and FD

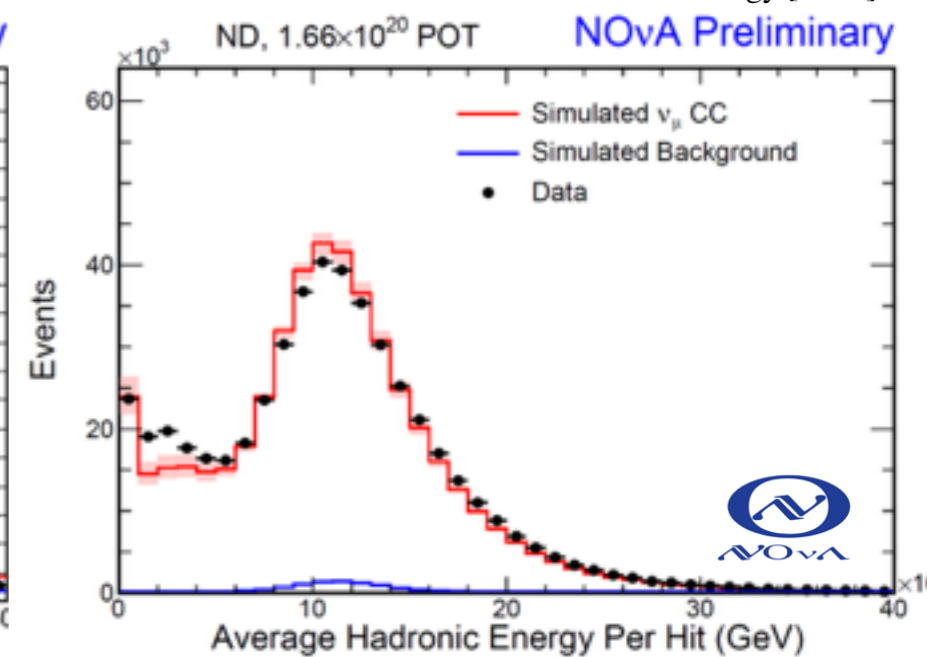
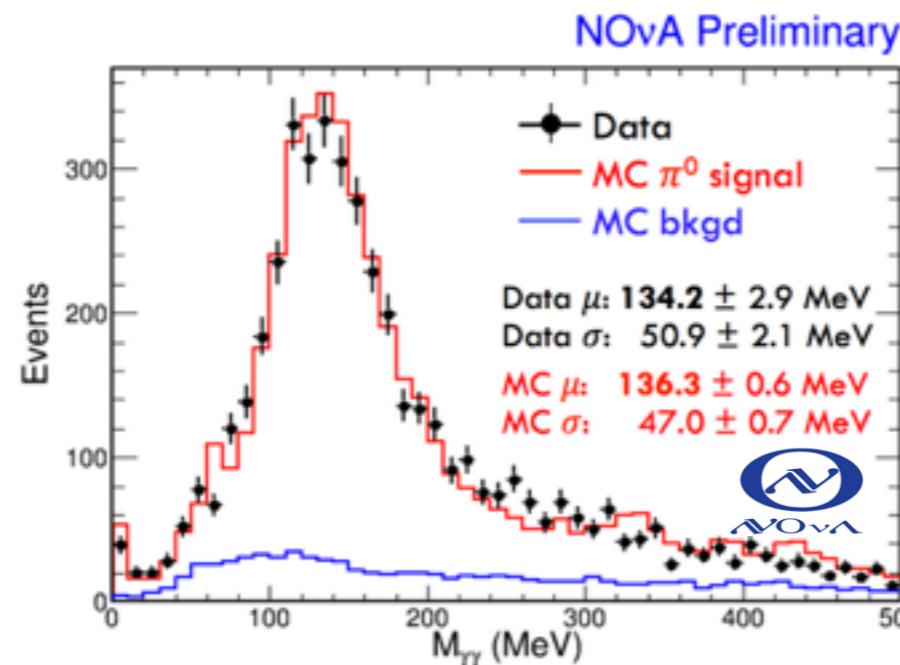

Detector modelling uncertainties typically from data MC comparisons in control samples
 May be limited by control sample statistics

T2K Systematic Uncertainties

ND280 constraint
13% → 3%

Error Source	μ sample [%]		e sample [%]	
	ν	$\bar{\nu}$	ν	$\bar{\nu}$
SK Detector	1.9	1.6	3.0	4.2
SK FSI+SI+PN	2.2	2.0	2.9	2.5
ND280 Constraint (Flux + Cross Section)	3.3	2.7	3.2	2.9
$\sigma(\nu_e)/\sigma(\nu_\mu)$	-	-	2.6	1.5
NC 1γ	-	-	1.1	2.6
NC other	0.3	0.1	0.1	0.3
Total Systematic	4.4	3.8	6.3	6.4
Statistical	6.5	12	12	40

T2K preliminary (final systematics pending)

Total systematic uncertainty
~4 - 6%

Smaller than stats. uncertainty
(for now!)

Pion Final State
Interactions (FSI) and
Secondary Interactions
(SI) modelling important

Theoretical uncertainty

ν_e to ν_μ

Difficult to constrain with
near detector

NOvA Systematic Uncertainties

ν_μ

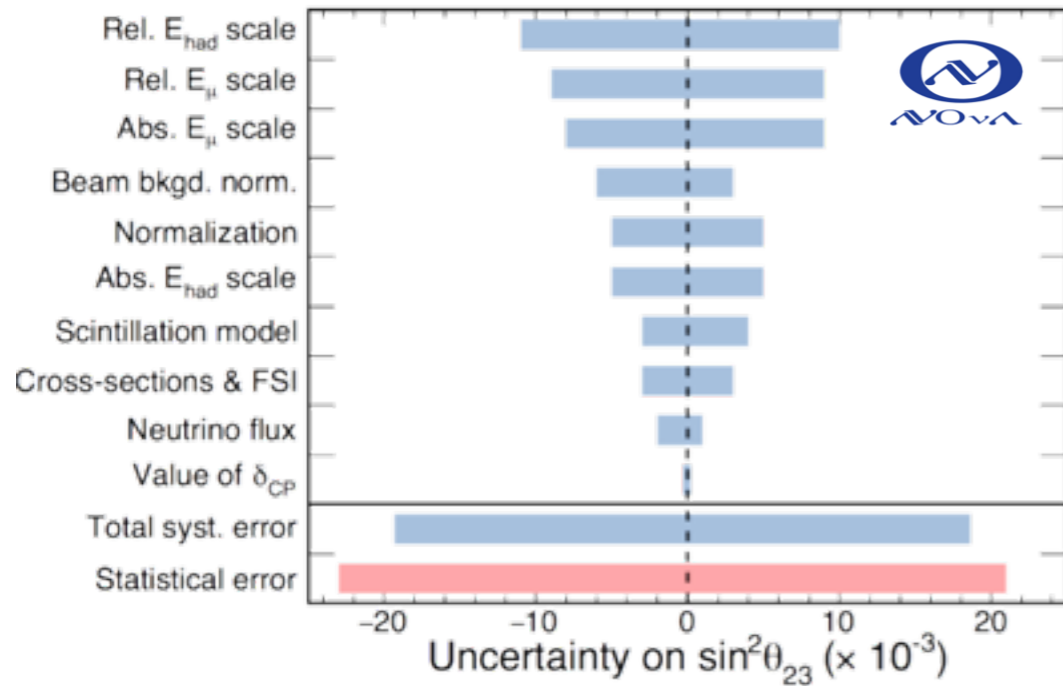

ν_e

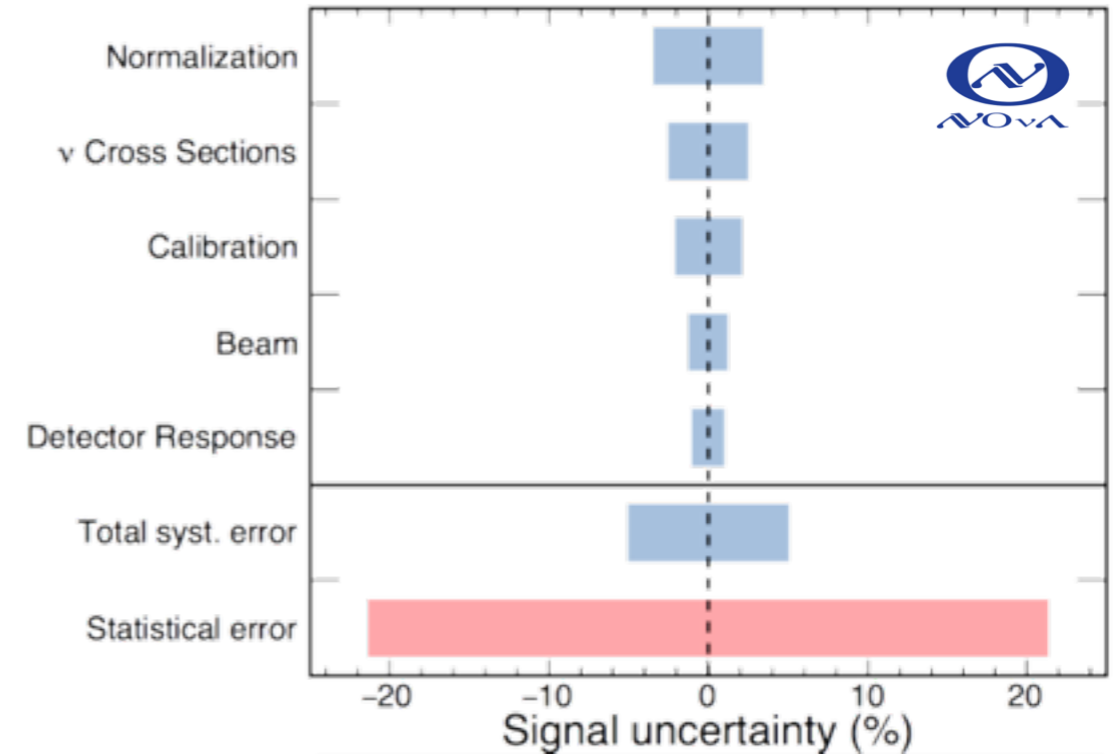

$\nu_e \sim 5-10\%$

$\nu_\mu \sim 3-4\%$

Energy scale uncertainties dominate ν_μ

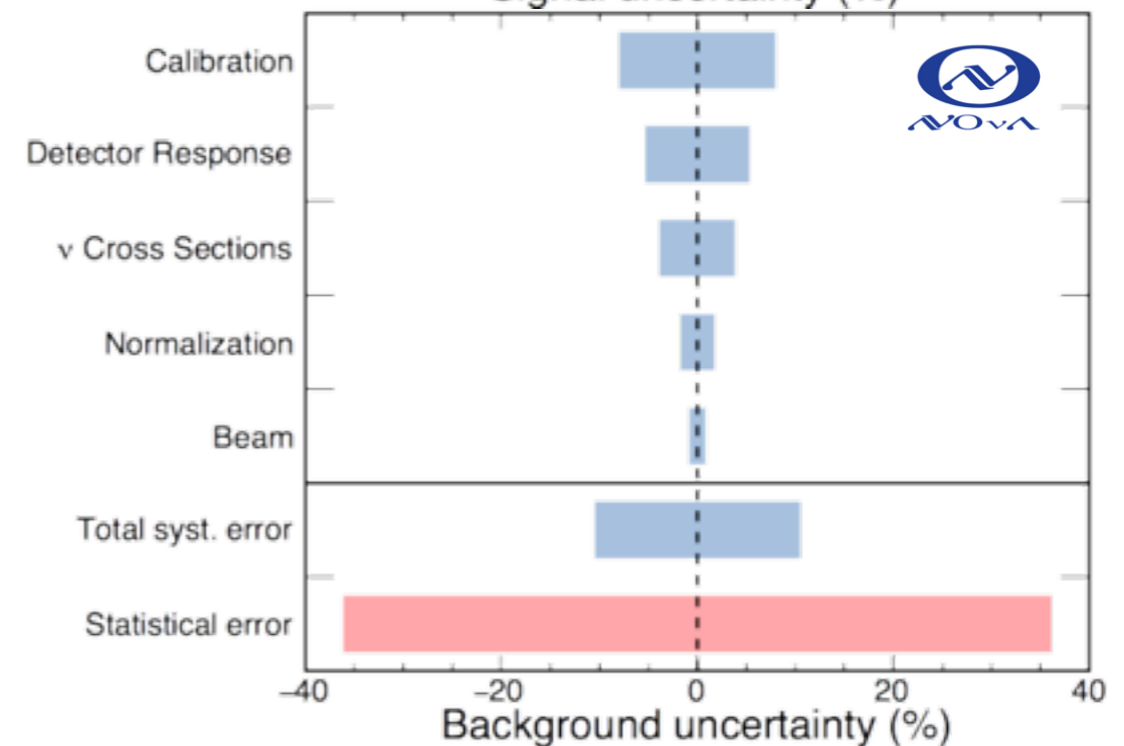

Near Detector Development

Planned ND280 Near Detector Upgrade

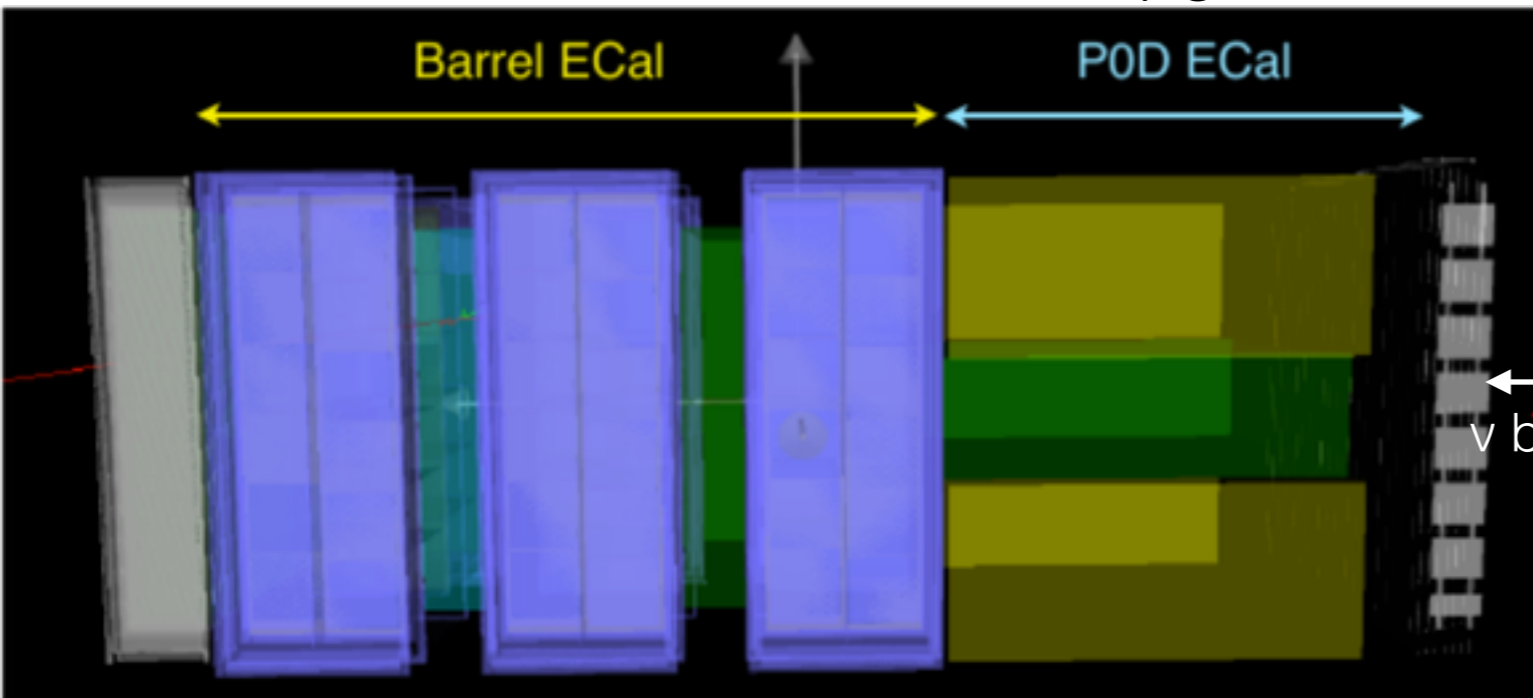

E61 Experiment

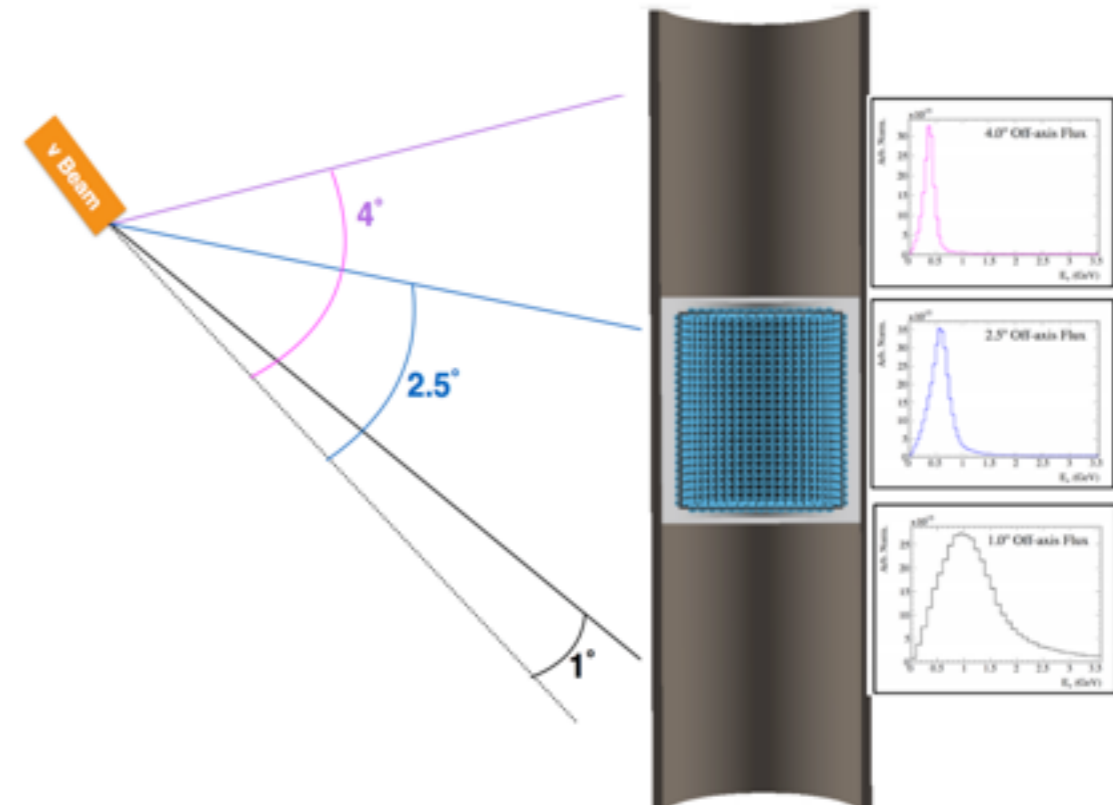

Near detector upgrades for T2K-II and T2HK era
New target with increased angular acceptance

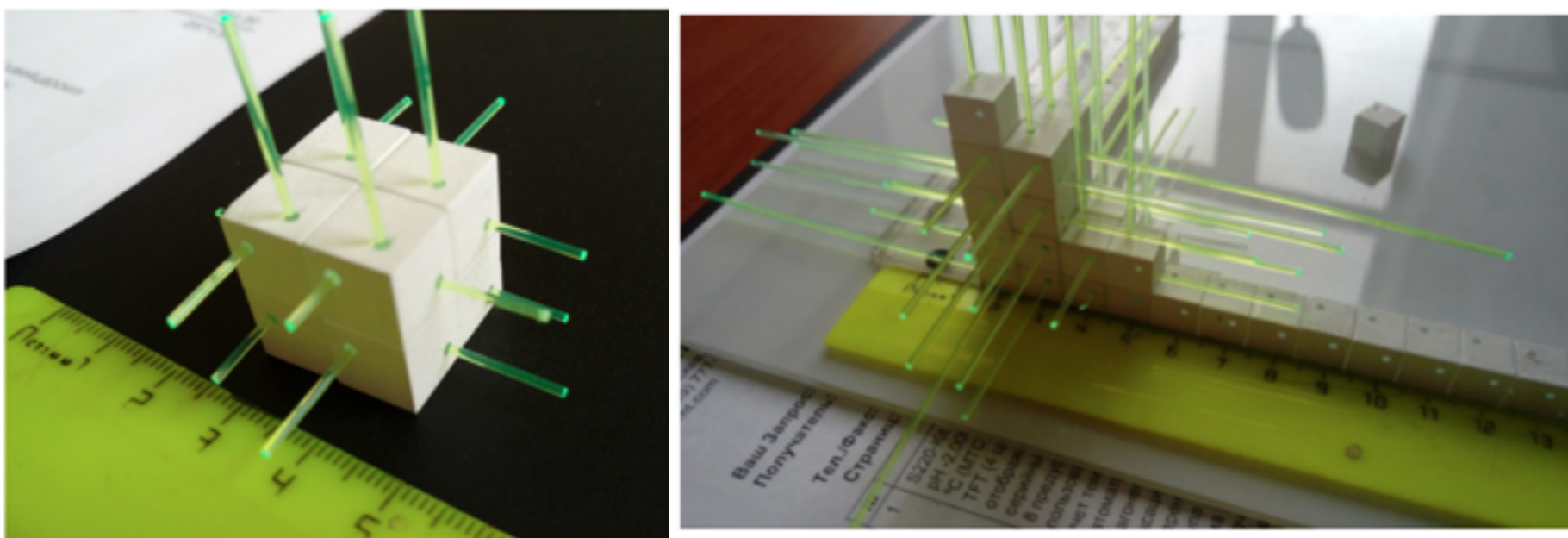

Intermediate Water-Cherenkov detector
Map detector response using multiple off-axis angles

Near Detector Development

Planned ND280 Near Detector Upgrade

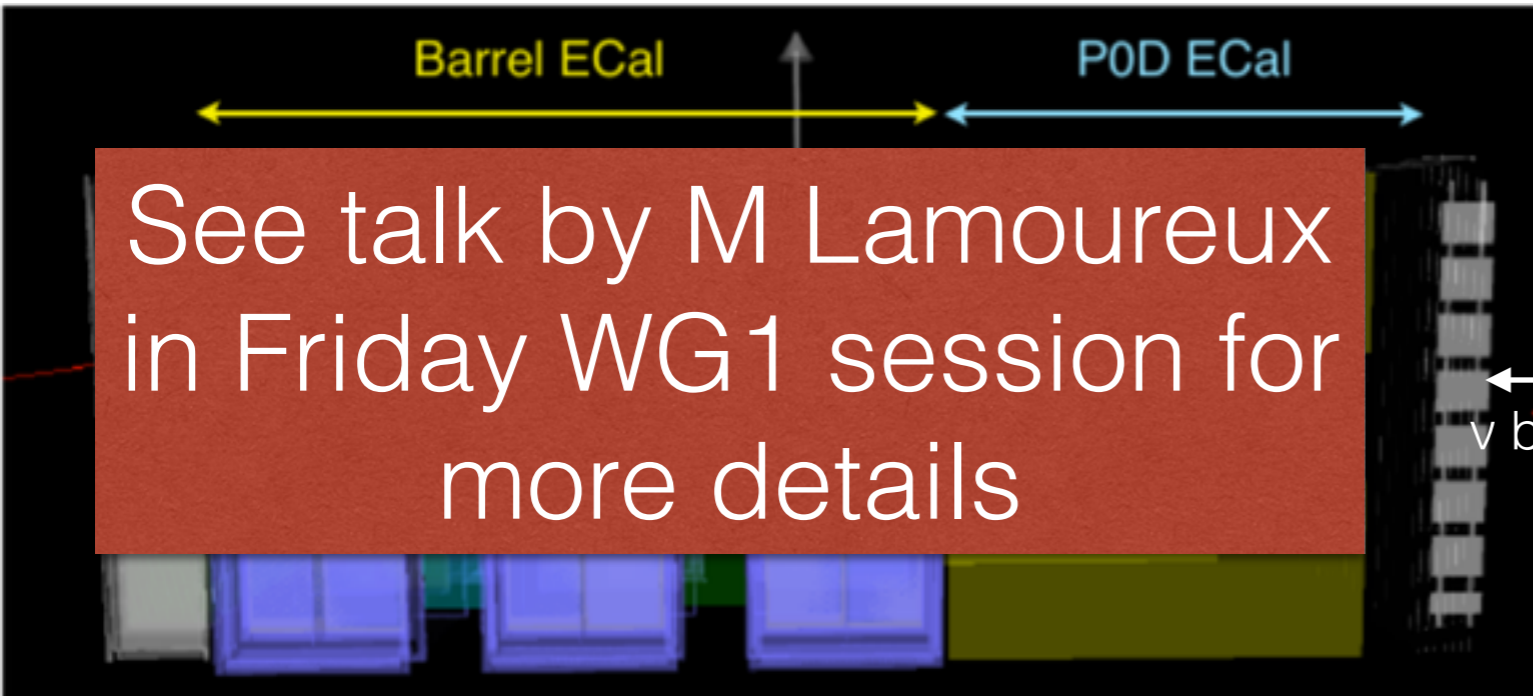

E61 Experiment

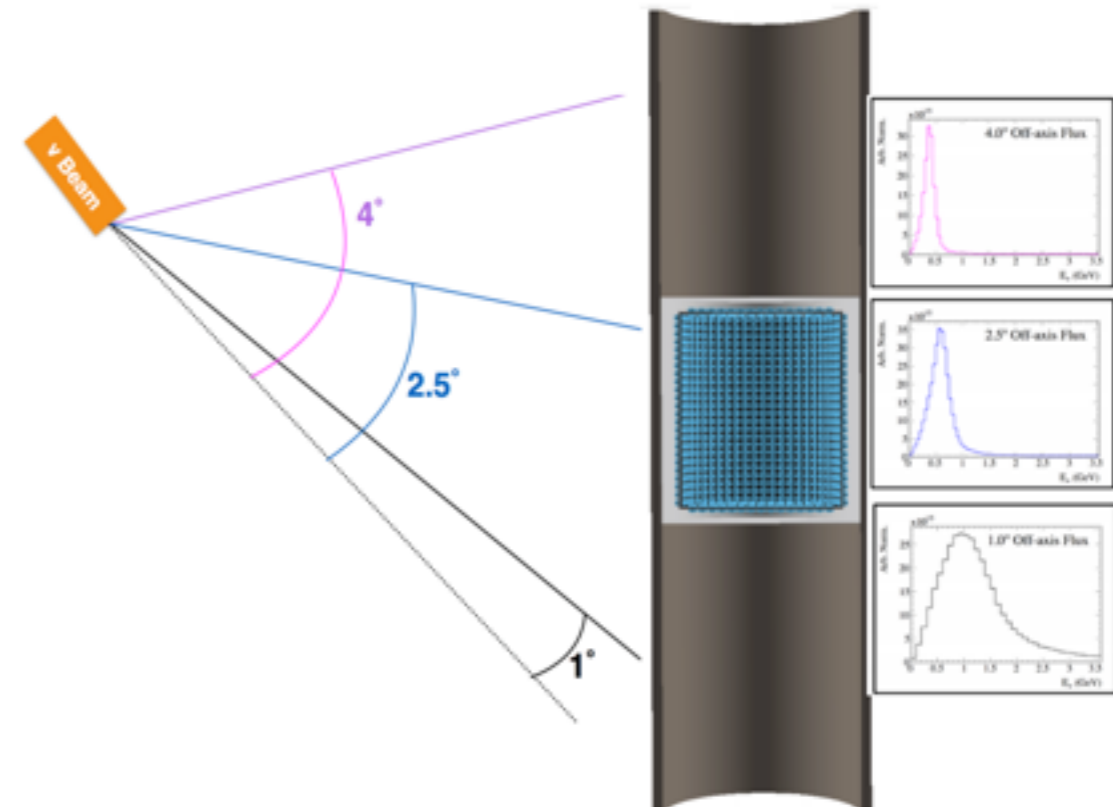

Near detector upgrades for T2K-II and T2HK era
New target with increased angular acceptance

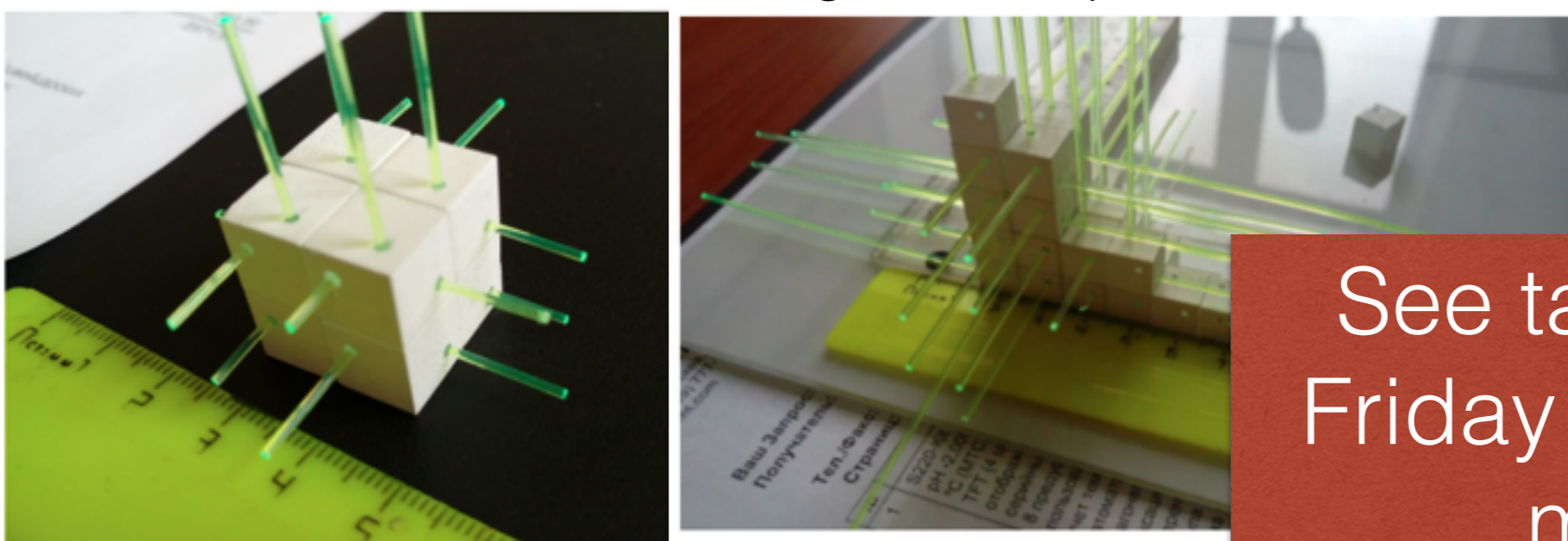

Intermediate Water-Cherenkov detector
Map detector response using multiple off-axis angles

See talk by C Vilela in Friday WG1 session for more details

Near Detector Development

Several Argon TPC experiments
Natural ND candidates for DUNE

Precisely image the neutrino interaction vertex
(better constraints on neutrino-nucleus
interaction models → better energy
measurement)

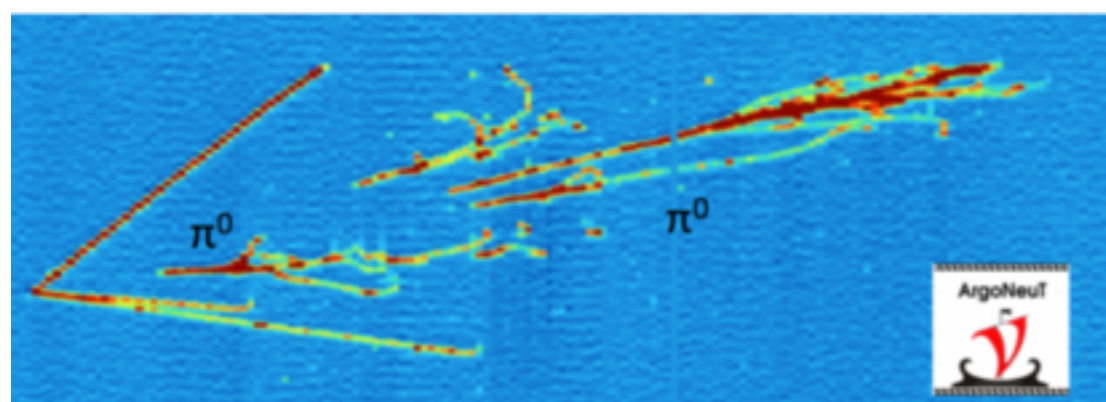
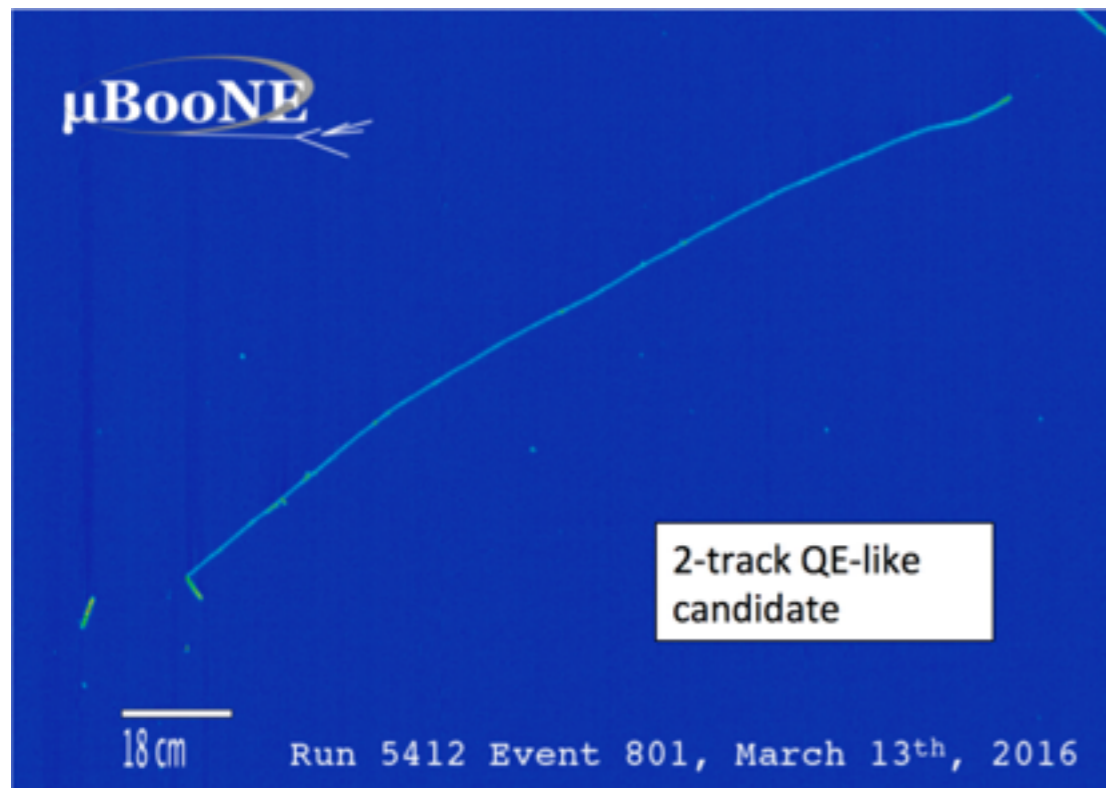

DUNE High Pressure Gaseous TPC ND

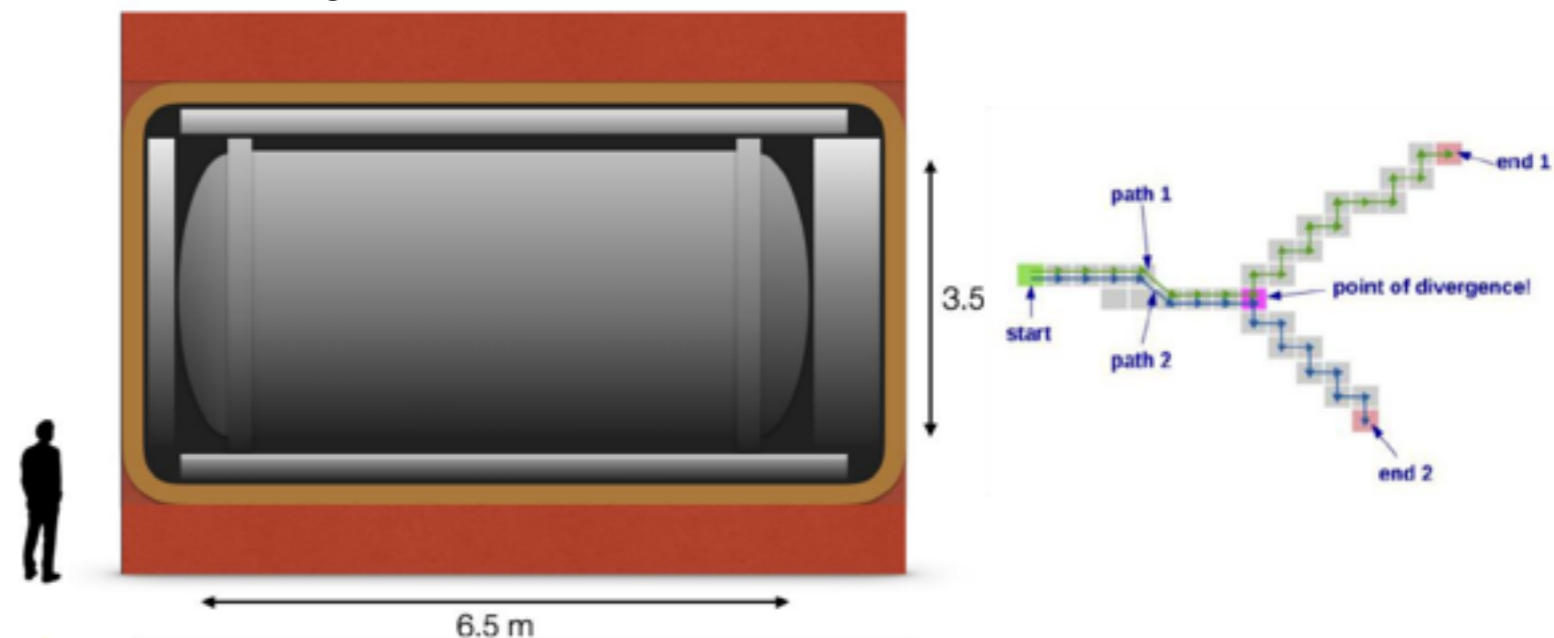

Ultra-low thresholds with gaseous TPC

Near Detector Development

Several Argon TPC experiments
Natural ND candidates for DUNE

See talk by H Duyang in Friday WG1 session for more details

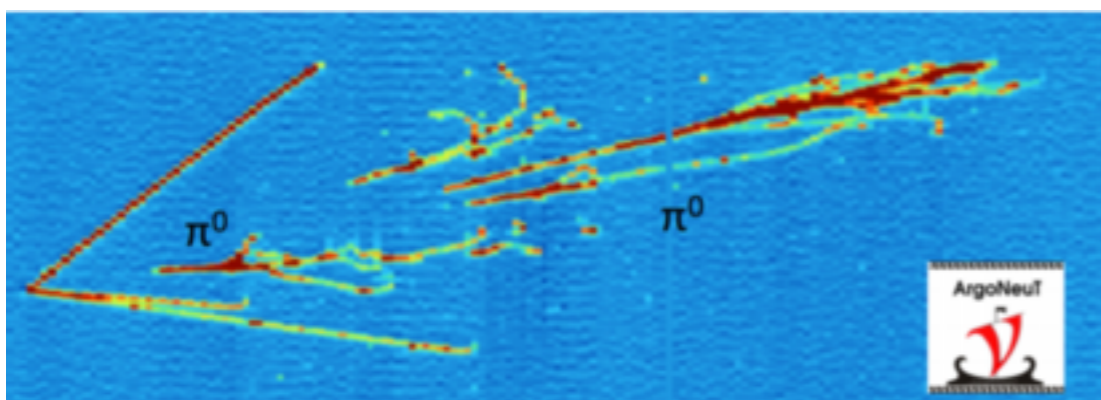
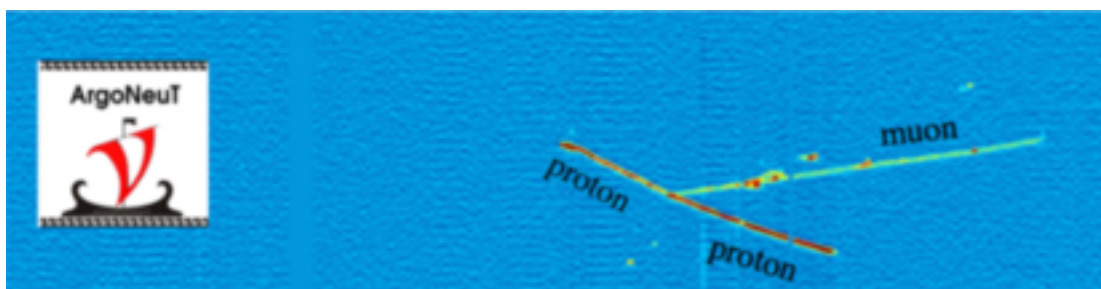
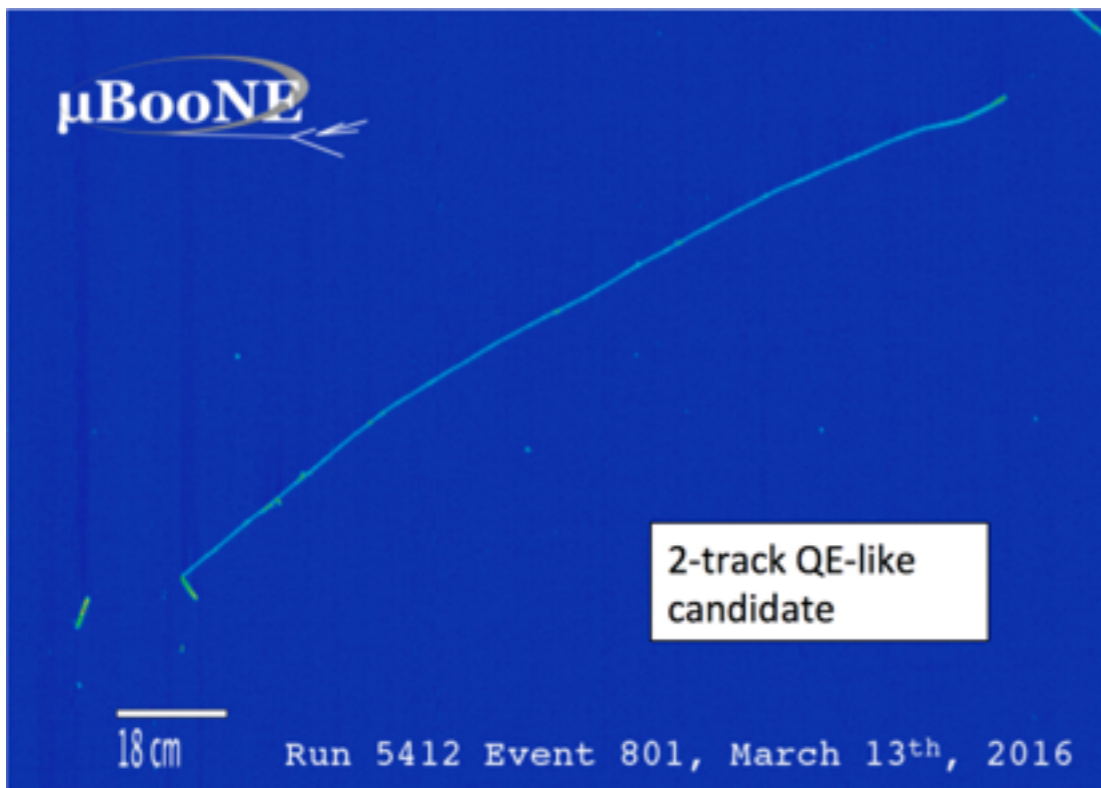

DUNE High Pressure Gaseous TPC ND

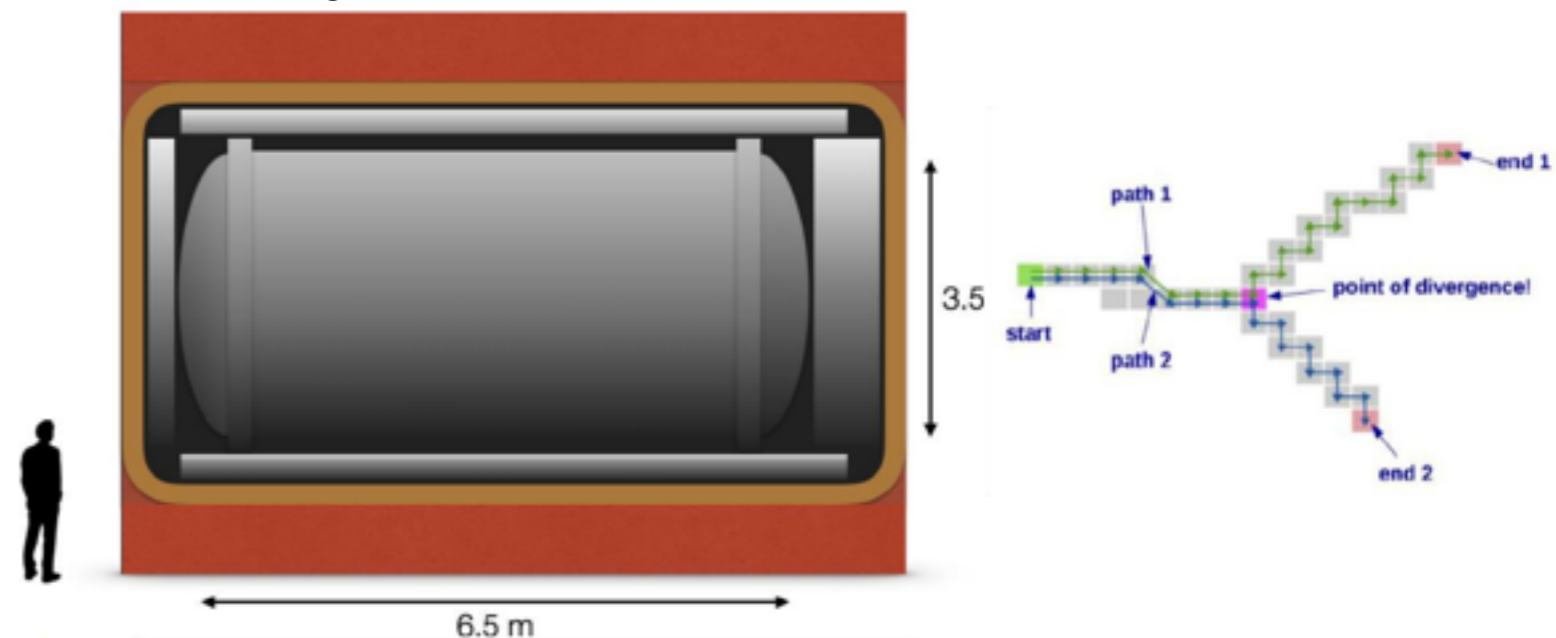

Ultra-low thresholds with gaseous TPC

Summary

Statistical precision promised by future high beam power and high mass experiments place high demands on the systematic uncertainties that experiments must reach

T2K and NOvA have reported systematics uncertainties in the range $\sim 3 - 10\%$ level

Reductions are needed today to make best use of the increasing statistical precision in the T2K and NOvA disappearance measurements

Improved flux determination, ν -nucleus interaction modelling and understanding of detector response will all play a role



Systematic Uncertainties in Accelerator-based Neutrino Oscillation Measurements

David Hadley

Systematic Uncertainties

Measurement of (potentially) small effects
requires high precision measurements

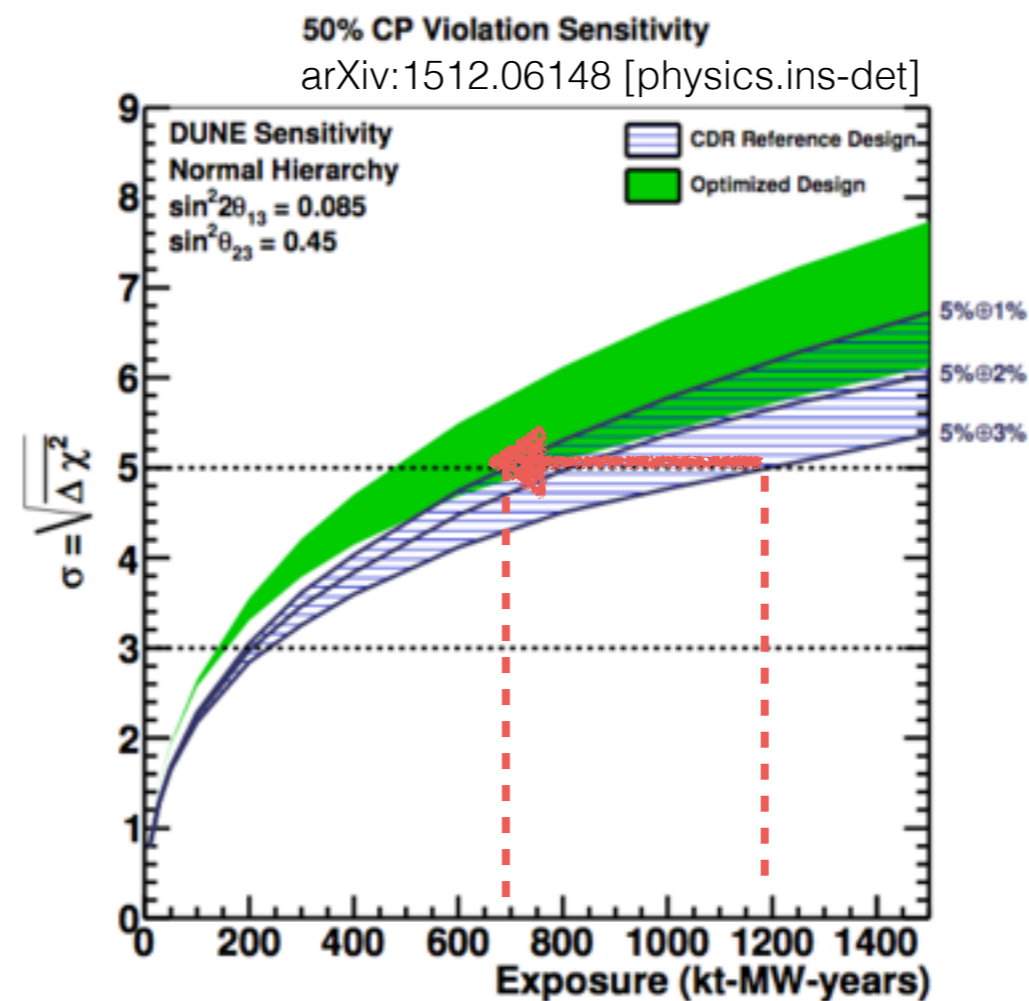

Reduction in systematic uncertainties
can be equivalent to significant boost
in exposure

Fake Data Studies

IMPACT ON CP PHASE



- Consider how changes to the $\Delta\chi^2$ impact intervals calculated from data
 - Shift $\Delta\chi^2$ observed in data (bottom plot) by difference observed in systematic study (top plot)
- **Maximum shift in the NH 2σ confidence interval mid-point was 1.7%**
- **Maximum change to the NH 2σ confidence interval was 2.3%**
- **Impact on δ_{CP} intervals is small**

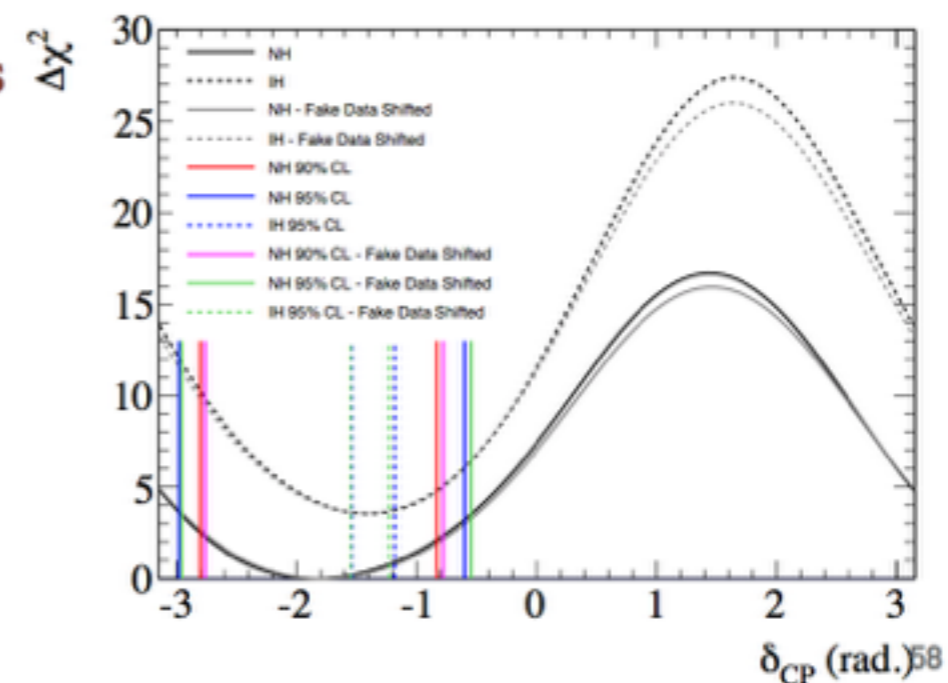
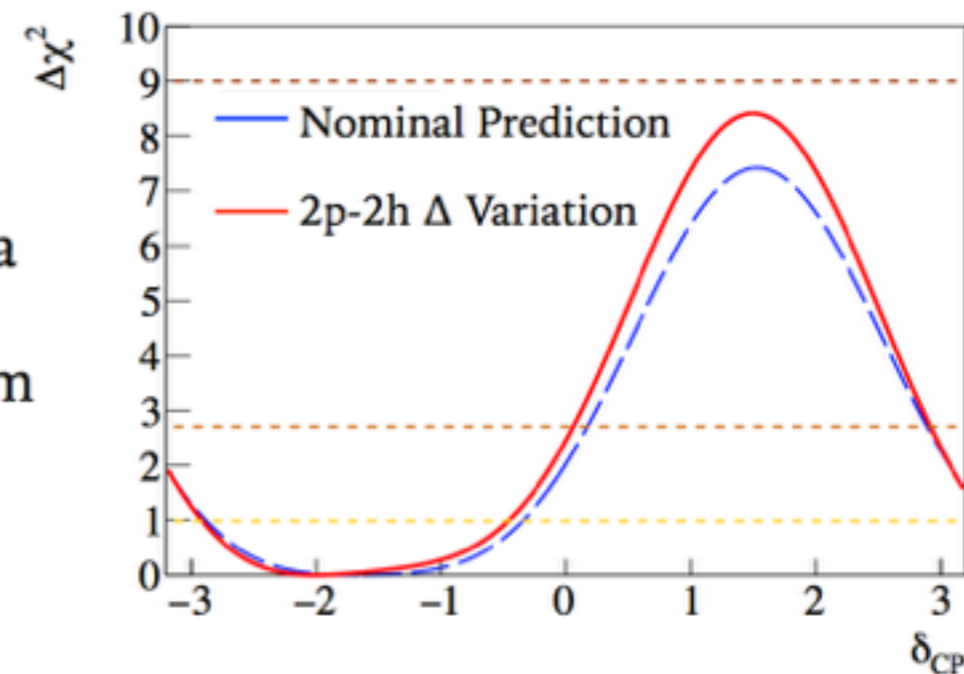

Fake Data Studies

IMPACT ON ATMOSPHERIC PARAMETERS



- ▶ In this study, Δm^2_{32} is biased to lower values
- ▶ $\sin^2\theta_{23}$ is biased towards maximal disappearance
 - ▶ Leads to narrower contour than fit to nominal prediction
- ▶ Shift towards maximal also seen in 1-D contour for oscillation parameter set B (bottom)

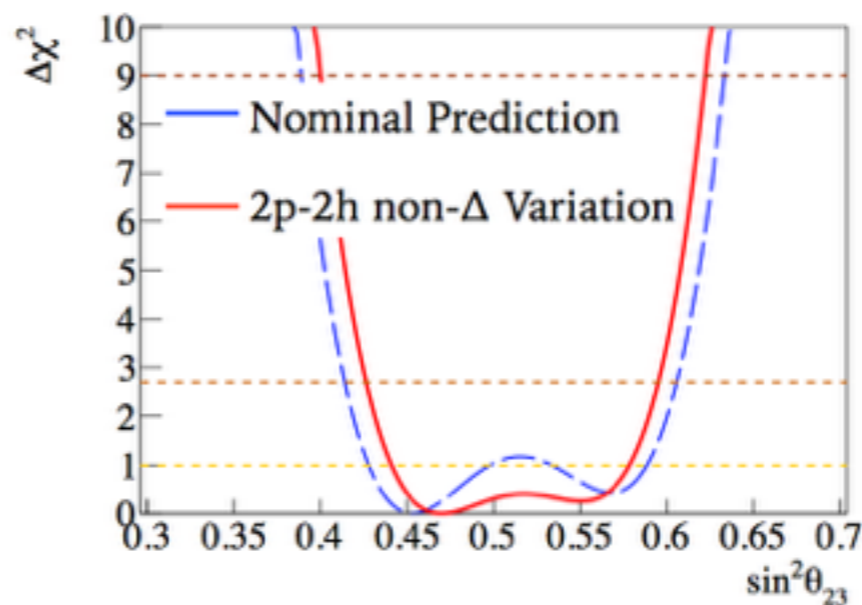
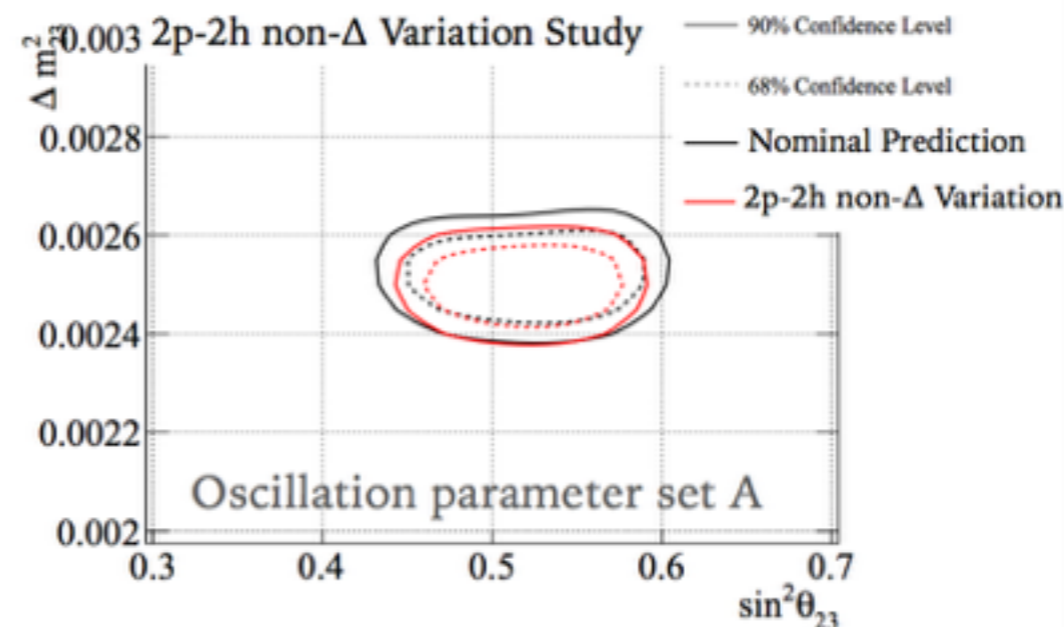

Fake Data Studies

ND280 DATA-DRIVEN VARIATION



➤ Take excess of data over prediction prior to ND280 fitting

➤ Assign excess to 1 of 3 types of interactions:

➤ CCQE

➤ 2p-2h Δ -enhanced

➤ 2p-2h non- Δ -enhanced

➤ Apply modeled excess to predict rates ND280 and SK

➤ Run fits

➤ **Effect seen on $\sin^2\theta_{23}$ and Δm^2_{32}**

➤ **No significant impact on the measured intervals for δ_{cp}**

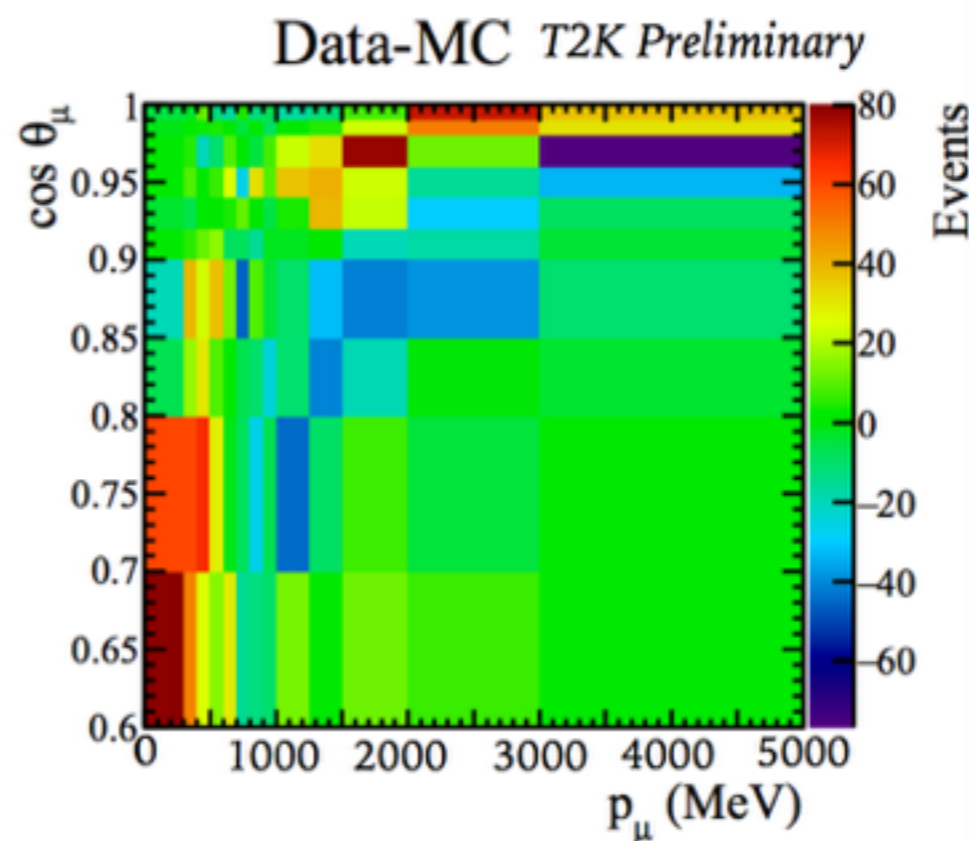

Super-Kamiokande

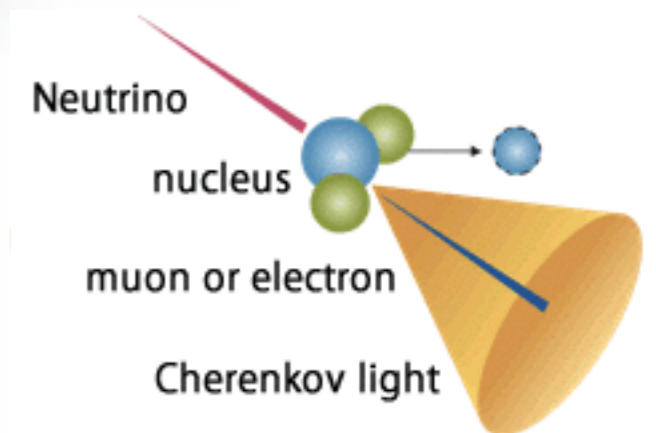
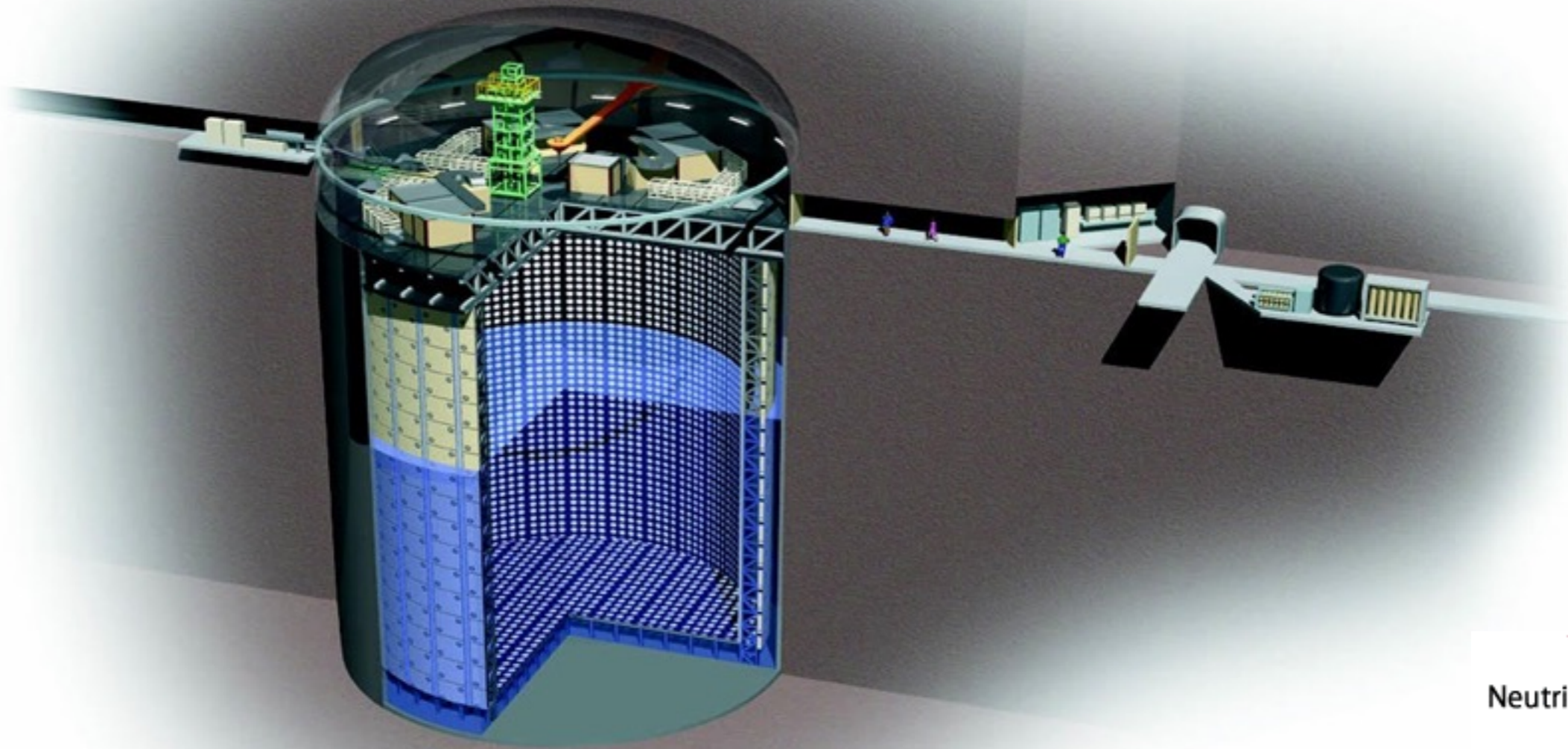

Water Cherenkov Detector
>22.5 kt fiducial mass

Water Cherenkov Technique

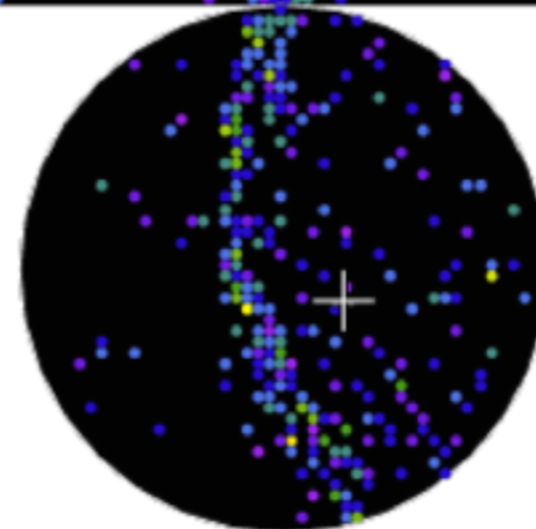
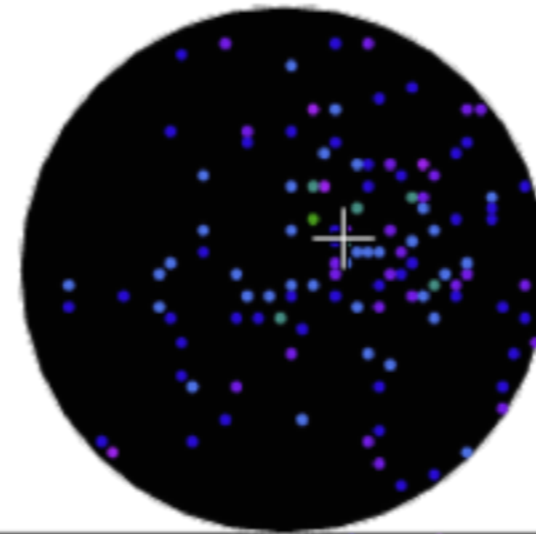
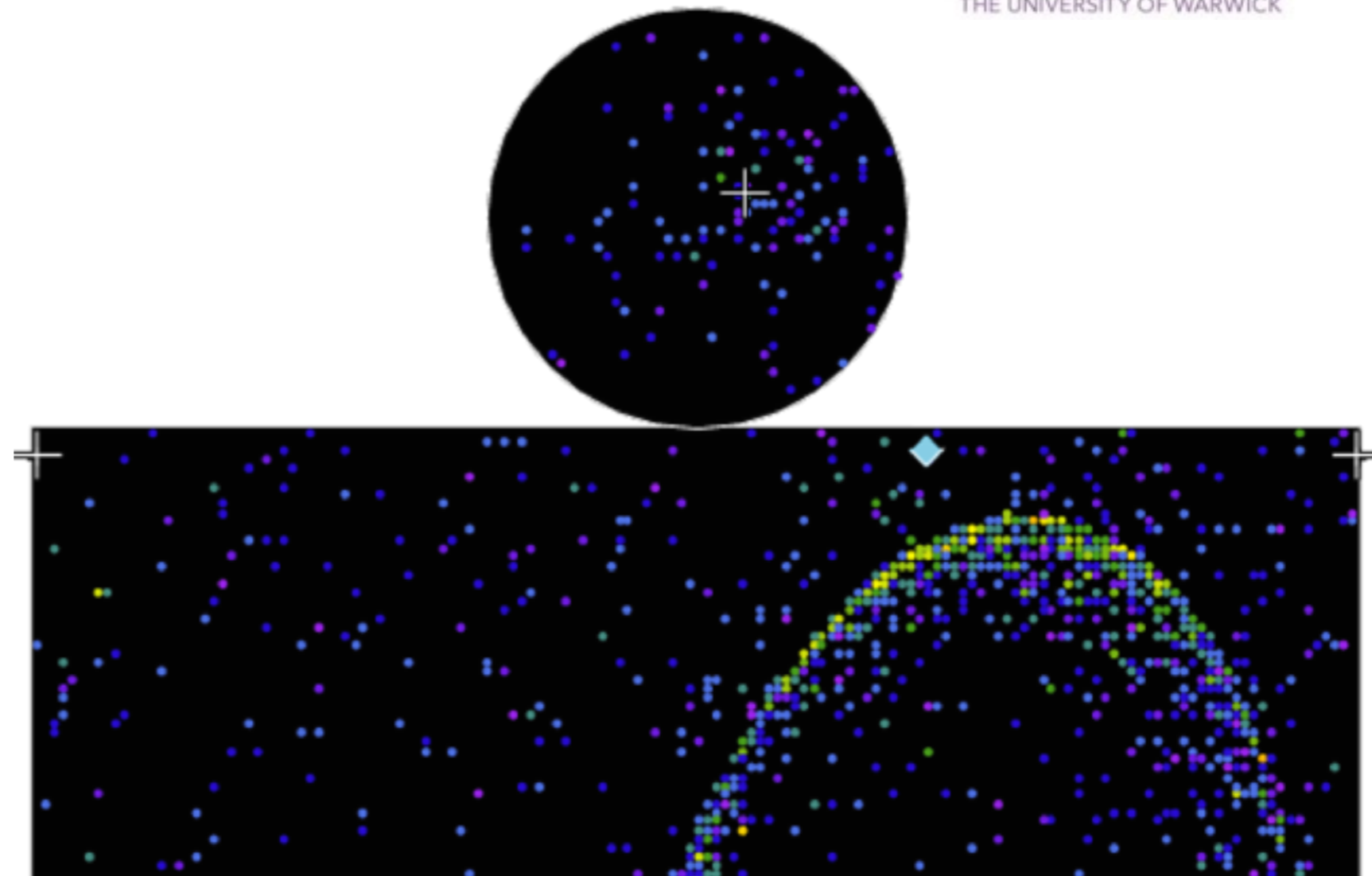

Muon

Water Cherenkov Technique

Muon

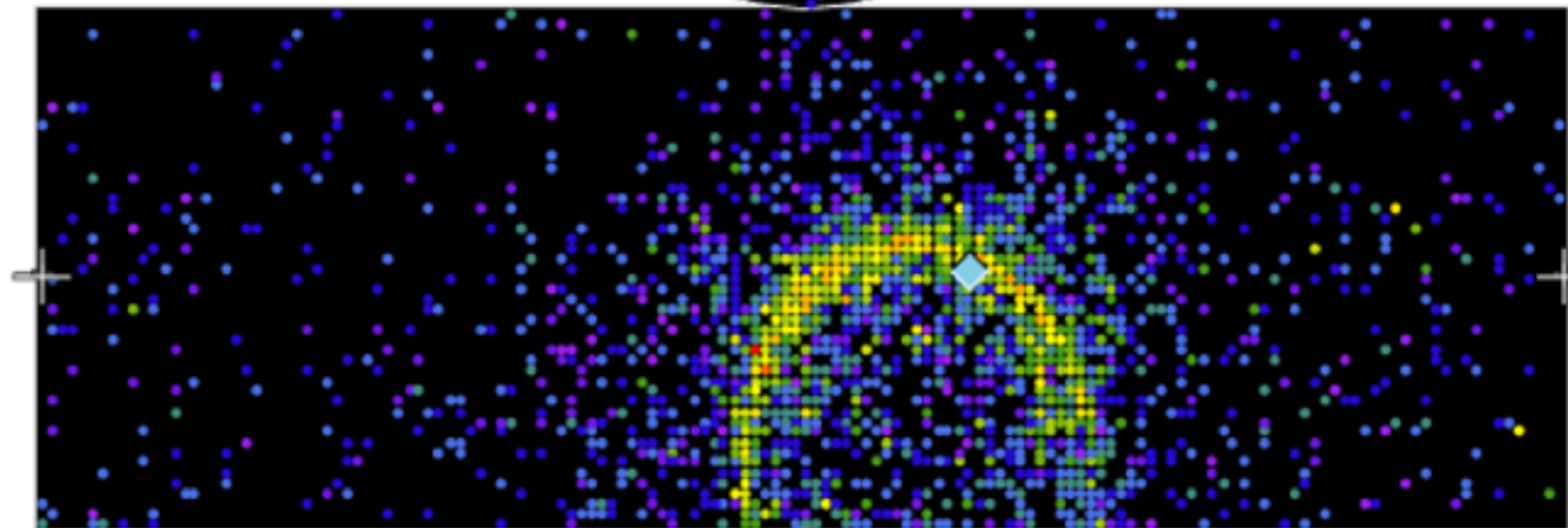
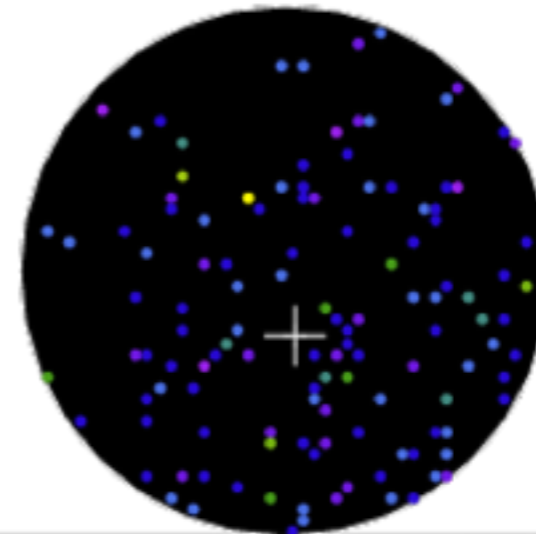
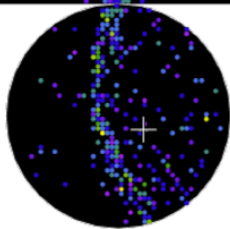
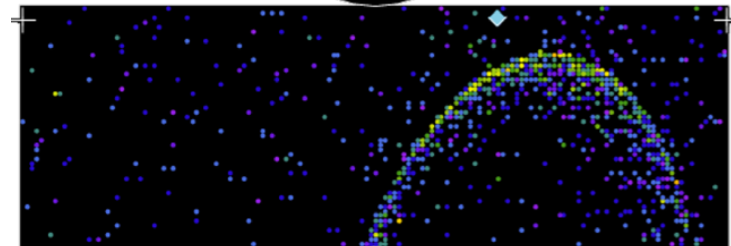
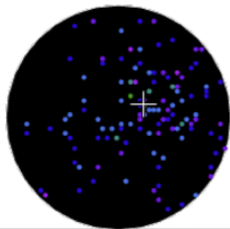

Electron

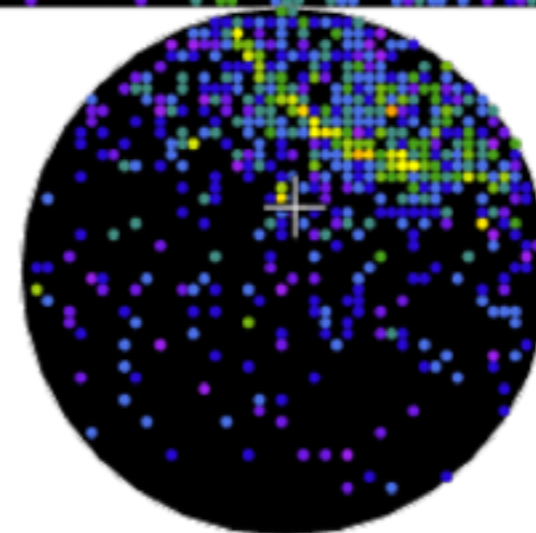

Water Cherenkov Technique

Muon

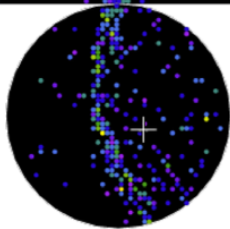
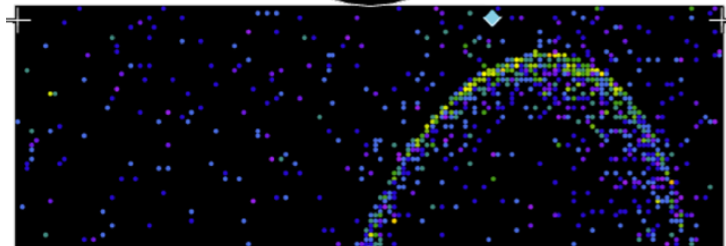
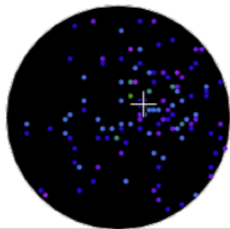

Electron

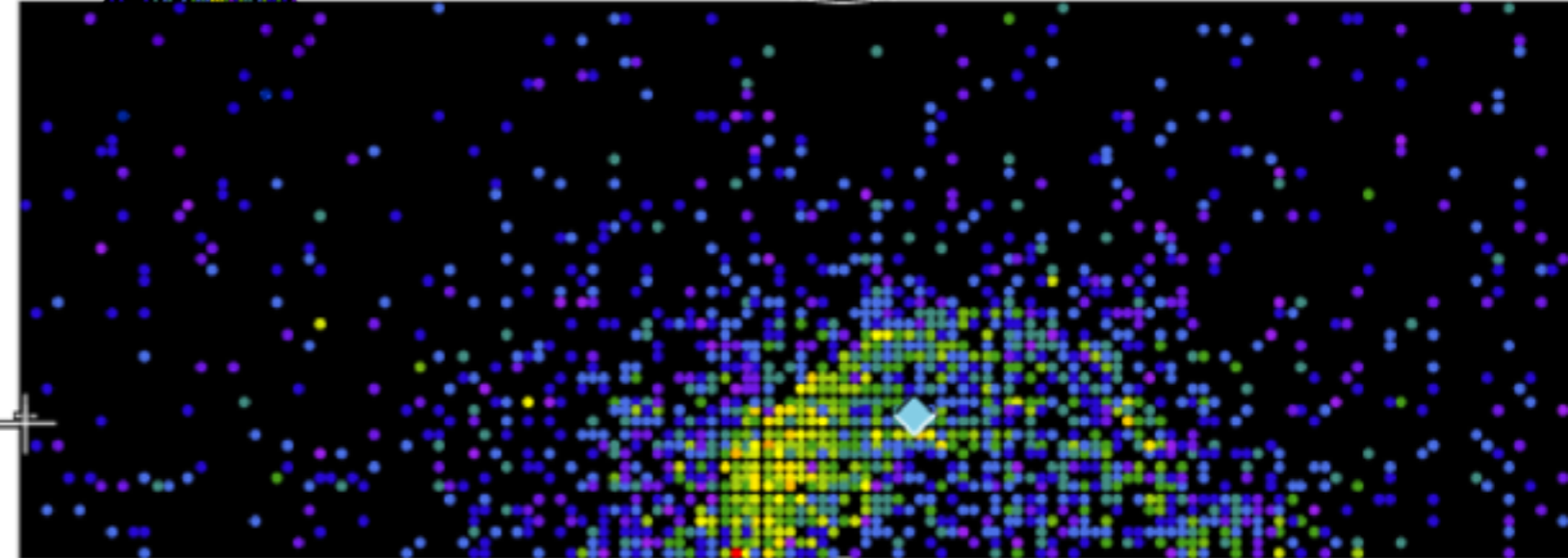
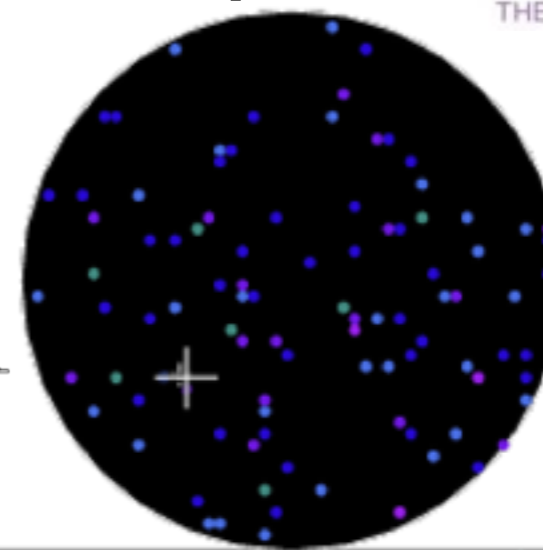
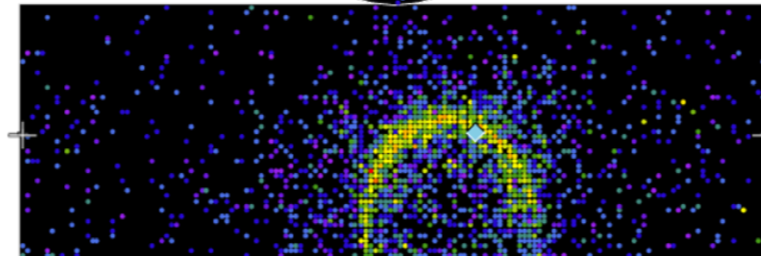
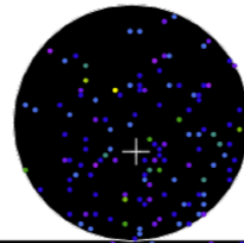

Neutral Pion

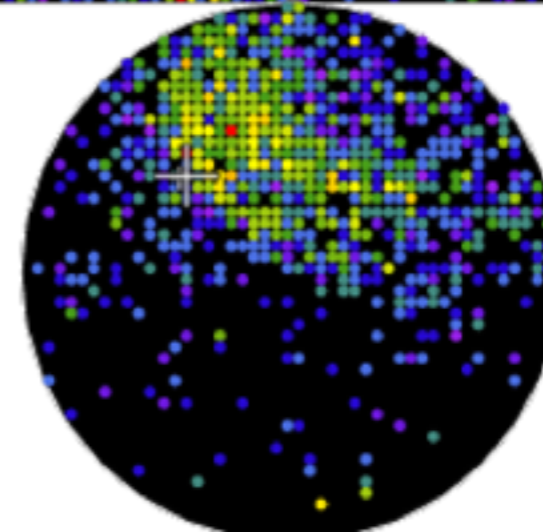

ND280 Flux

Phys. Rev. D 87, 092003 (2013)

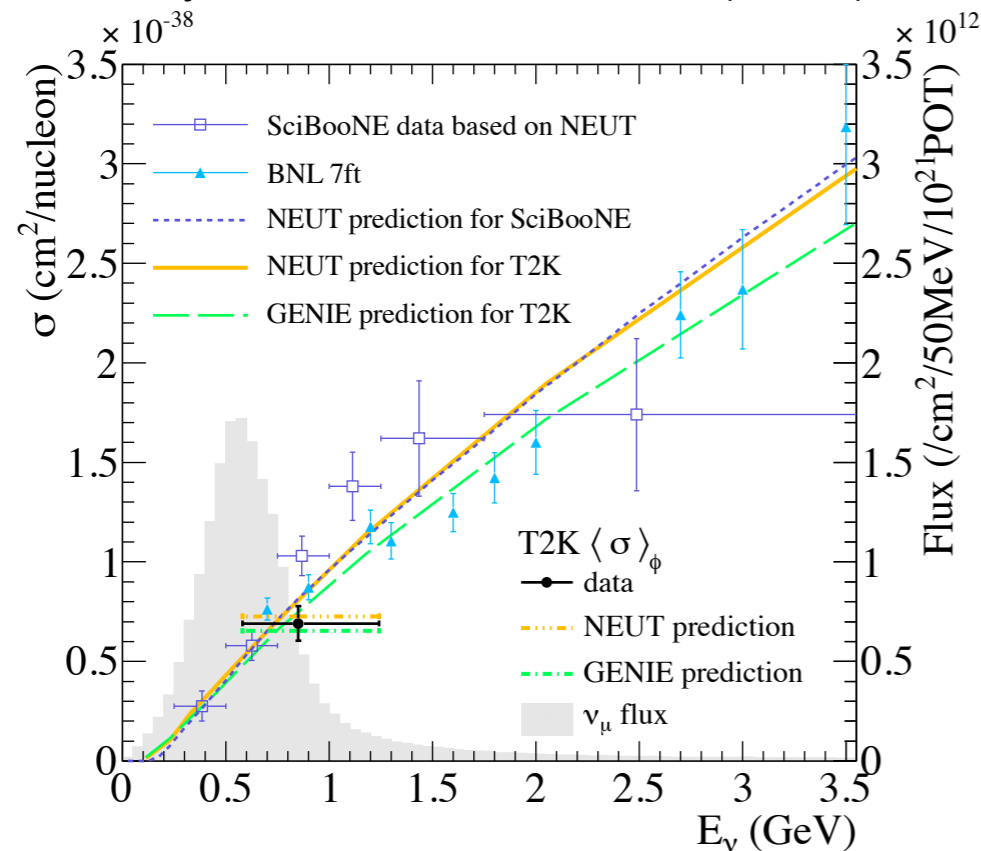

Phys. Rev. Lett. 113, 241803 (2014)

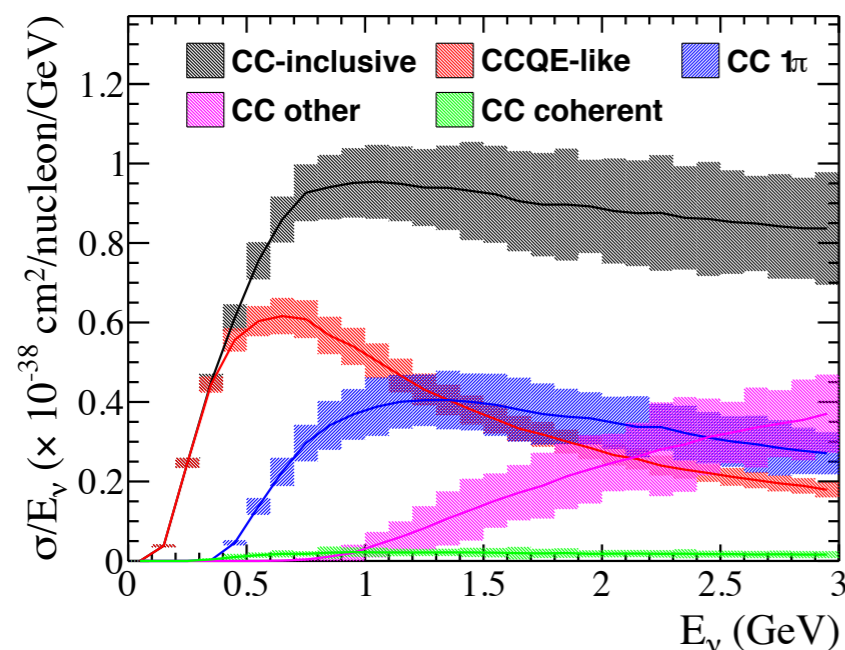
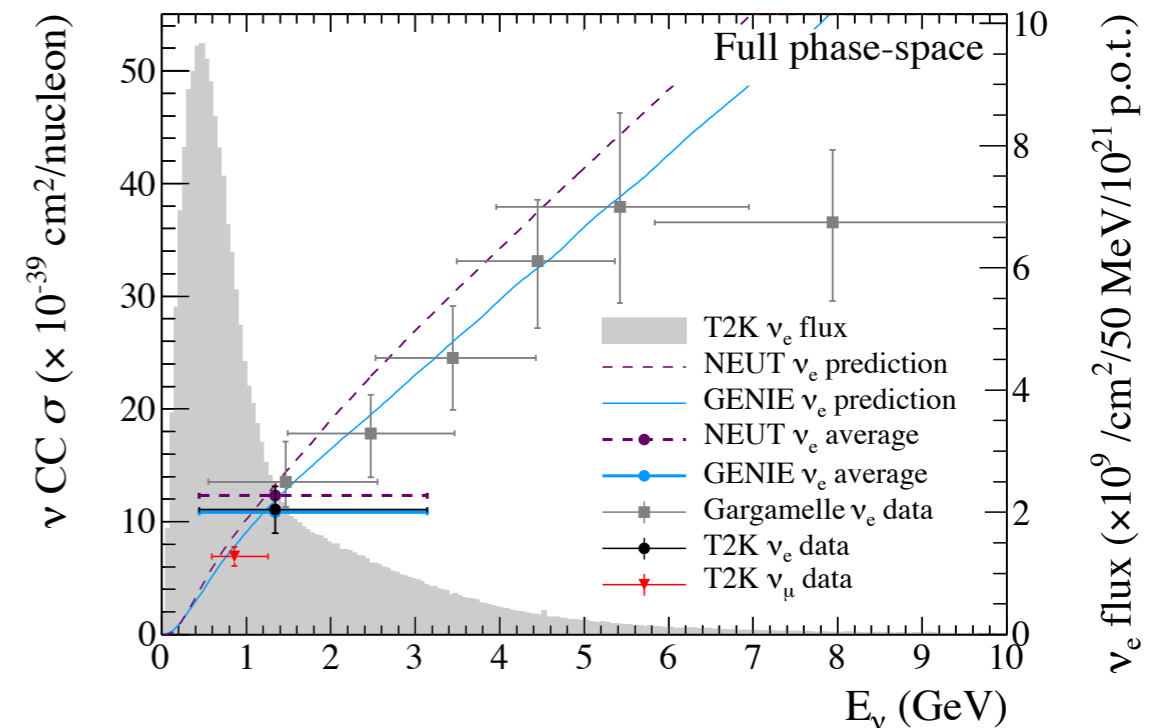

In neutrino-mode

ν_μ : $\langle E \rangle = 0.85$ GeV, ($\sim 90\%$)

ν_e : $\langle E \rangle = 1.3$ GeV, ($\sim 1\%$)

Dominant Reaction: CCQE
Single Pion Production

Flux at ND280

Neutrino Mode Flux at ND280

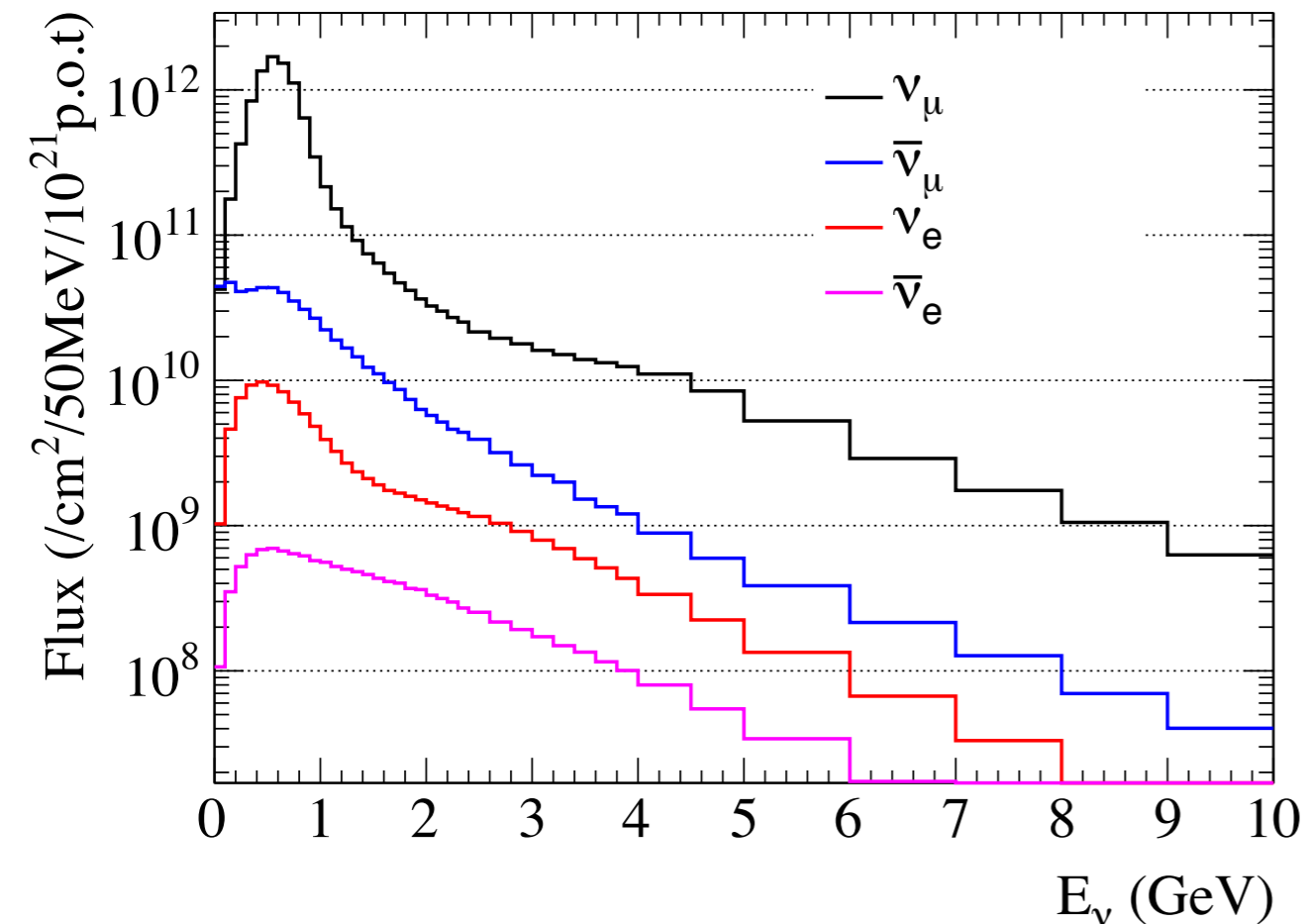

Antineutrino Mode Flux at ND280

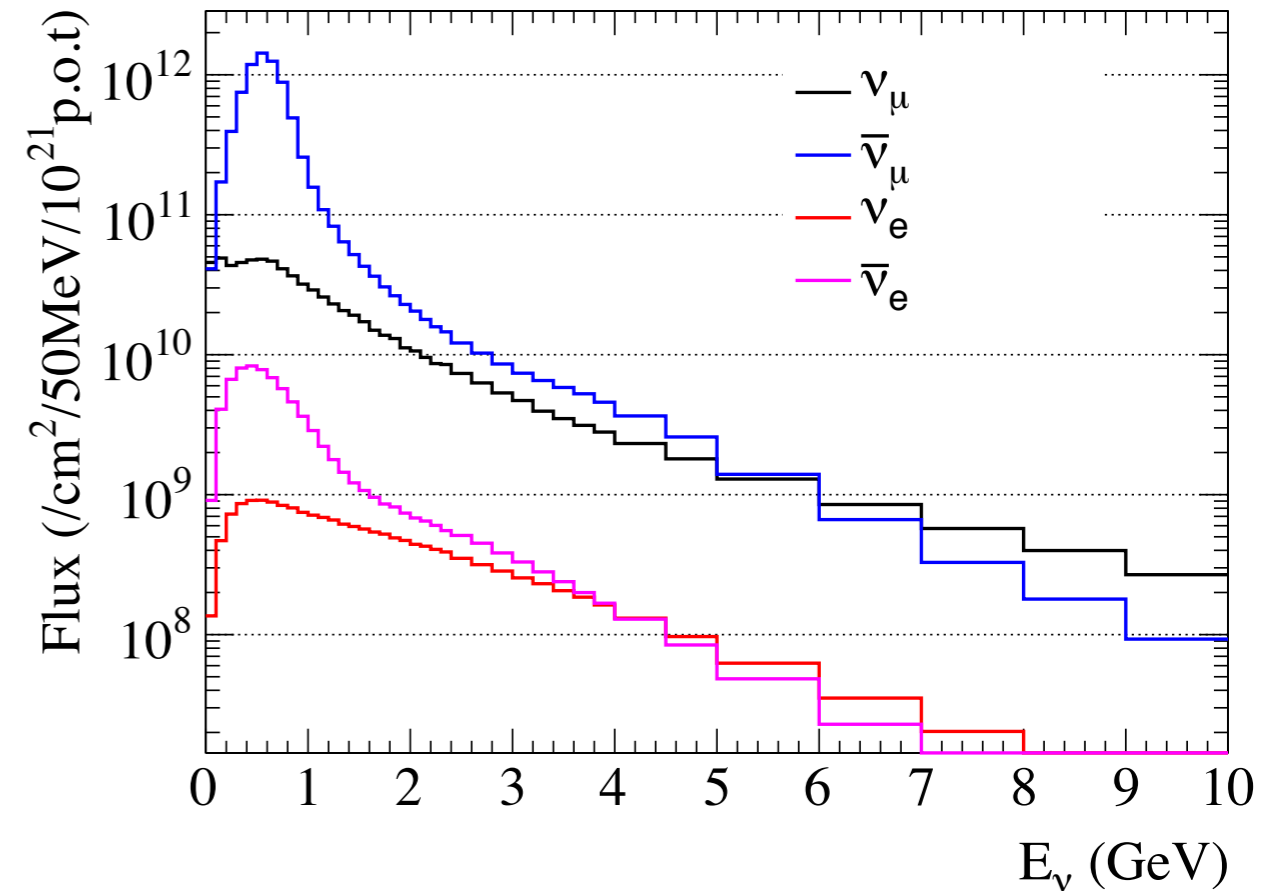

In neutrino-mode
 ν_μ : $\langle E \rangle = 0.85$ GeV, ($\sim 90\%$)
 ν_e : $\langle E \rangle = 1.3$ GeV, ($\sim 1\%$)

Dominant Reaction: CCQE
Single Pion Production

Flux at Super-K

Neutrino Mode Flux at SK

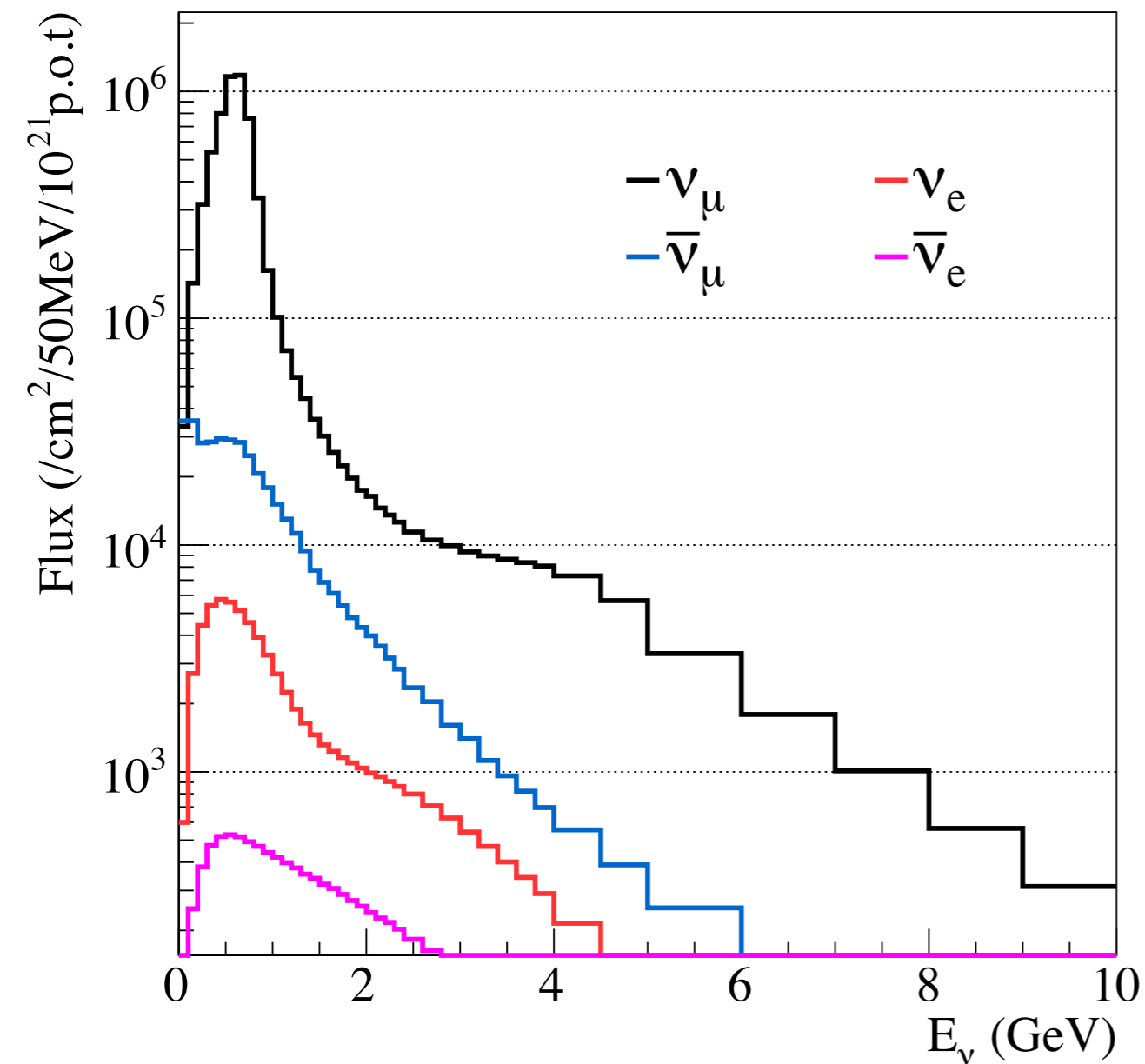

Antineutrino Mode Flux at SK

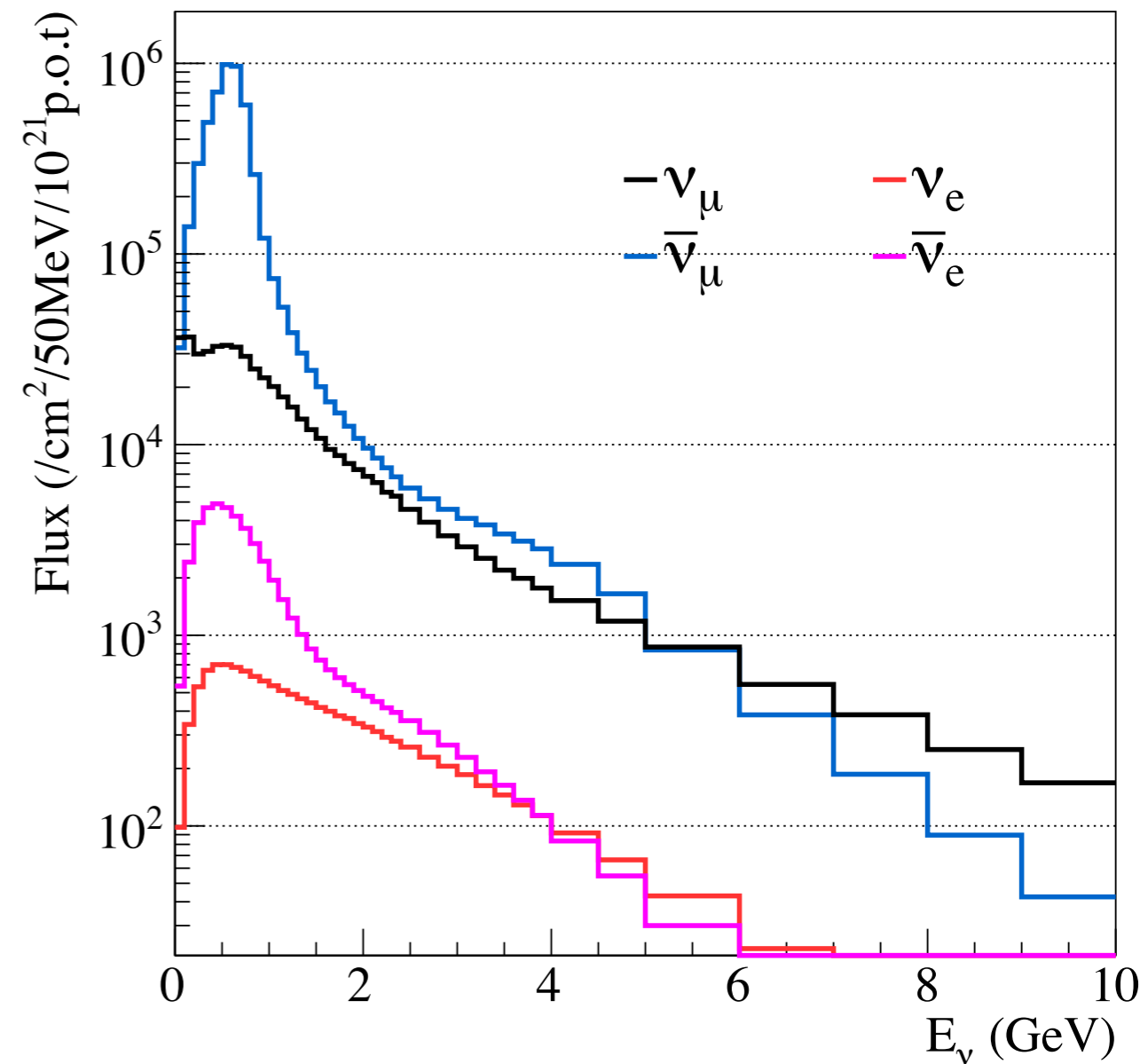

Flux Uncertainty

SK: Neutrino Mode, ν_μ

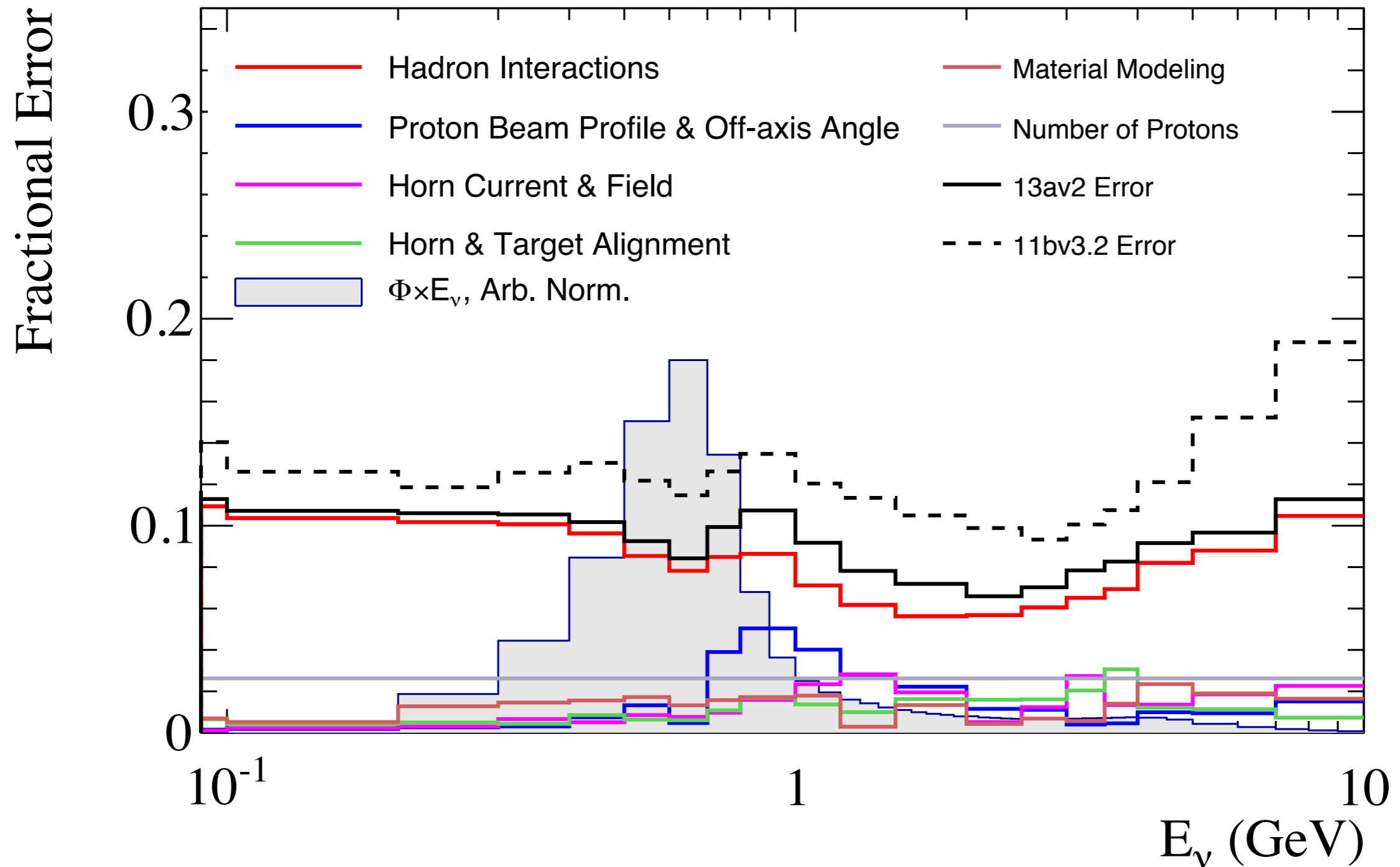

Flux Uncertainty

L Aliaga Soplin, NuInt 2017

NOvA Simulation

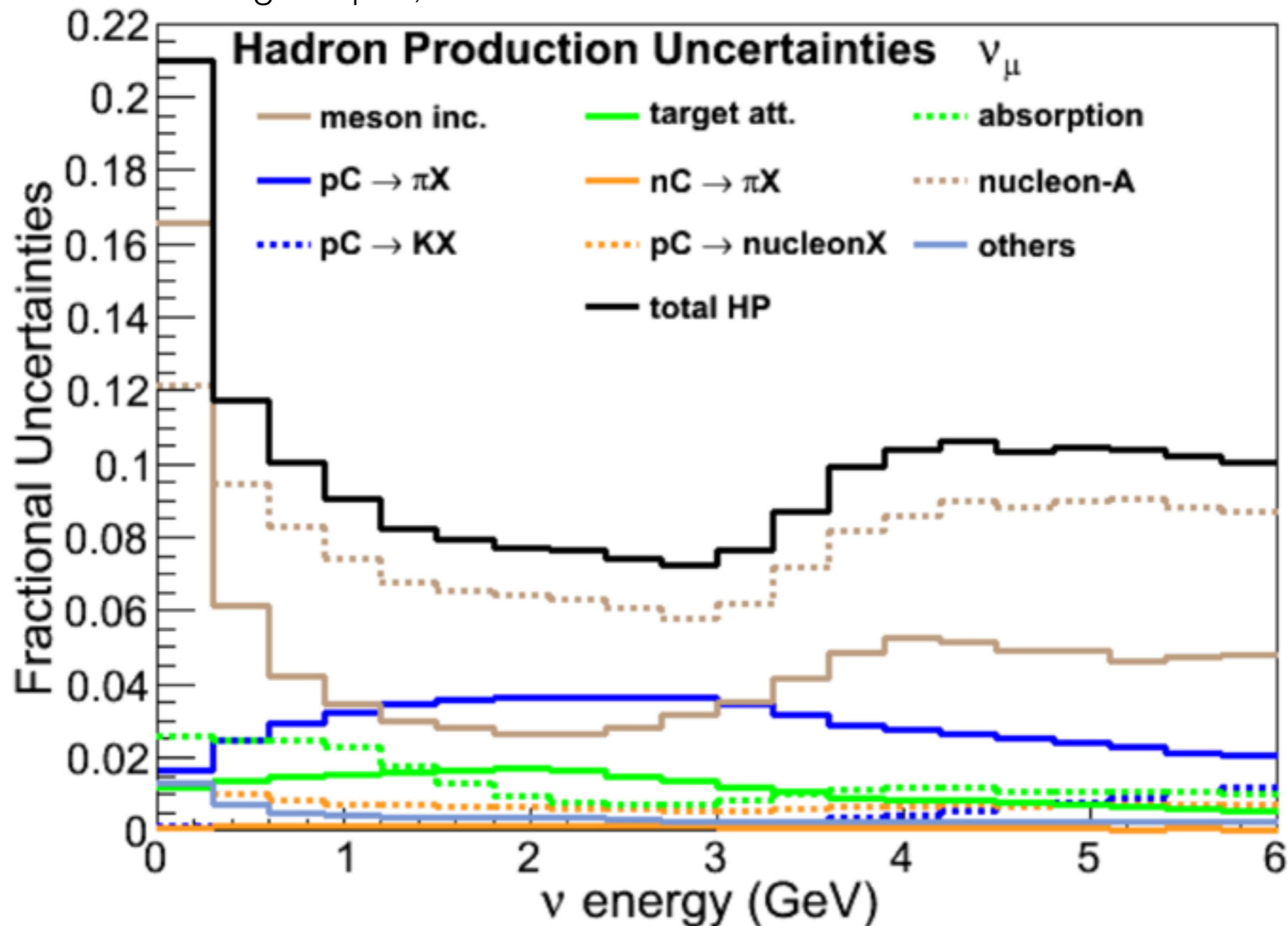

Flux at ND280

ND280: Neutrino Mode, ν_μ

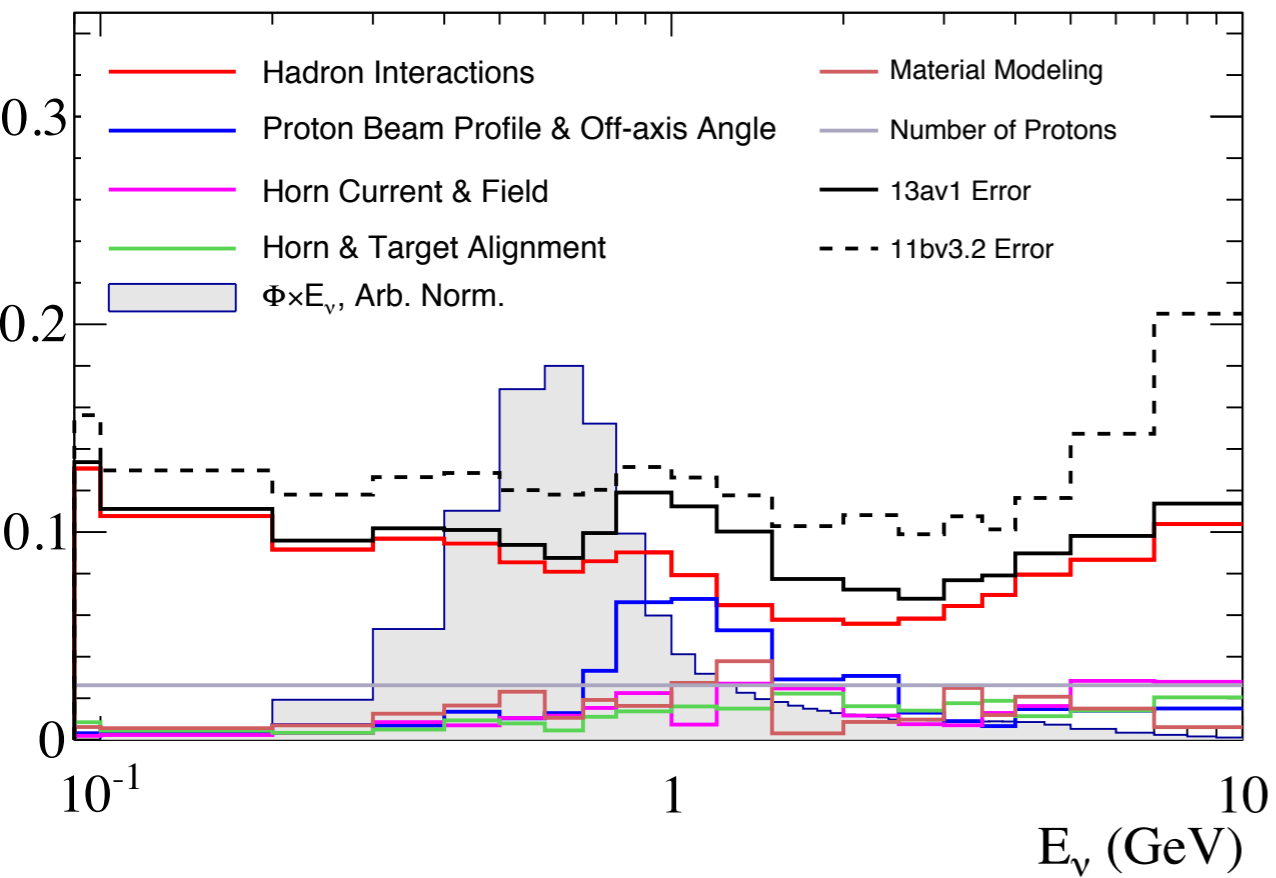

ND280: Antineutrino Mode, $\bar{\nu}_\mu$

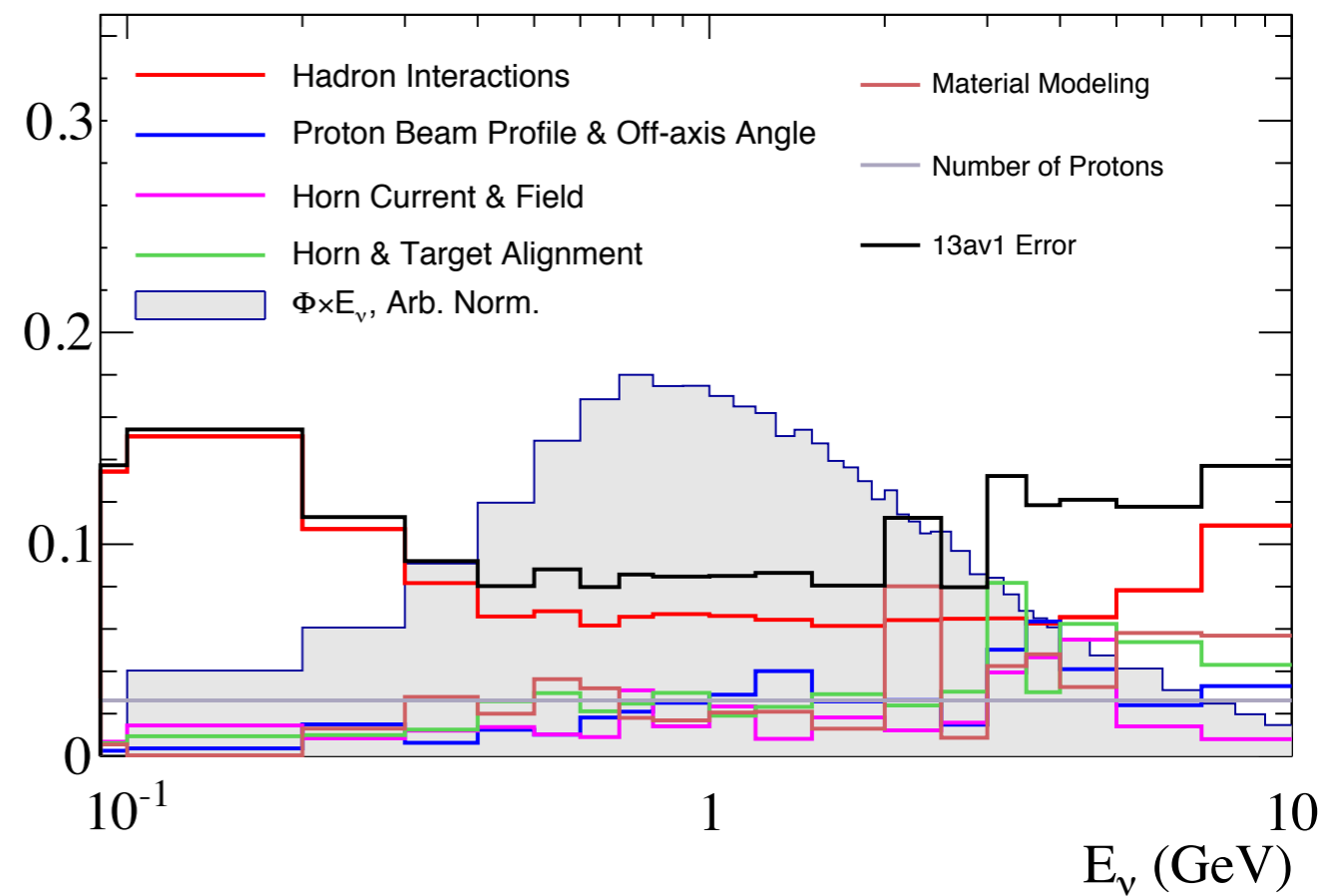

ND280 Detector

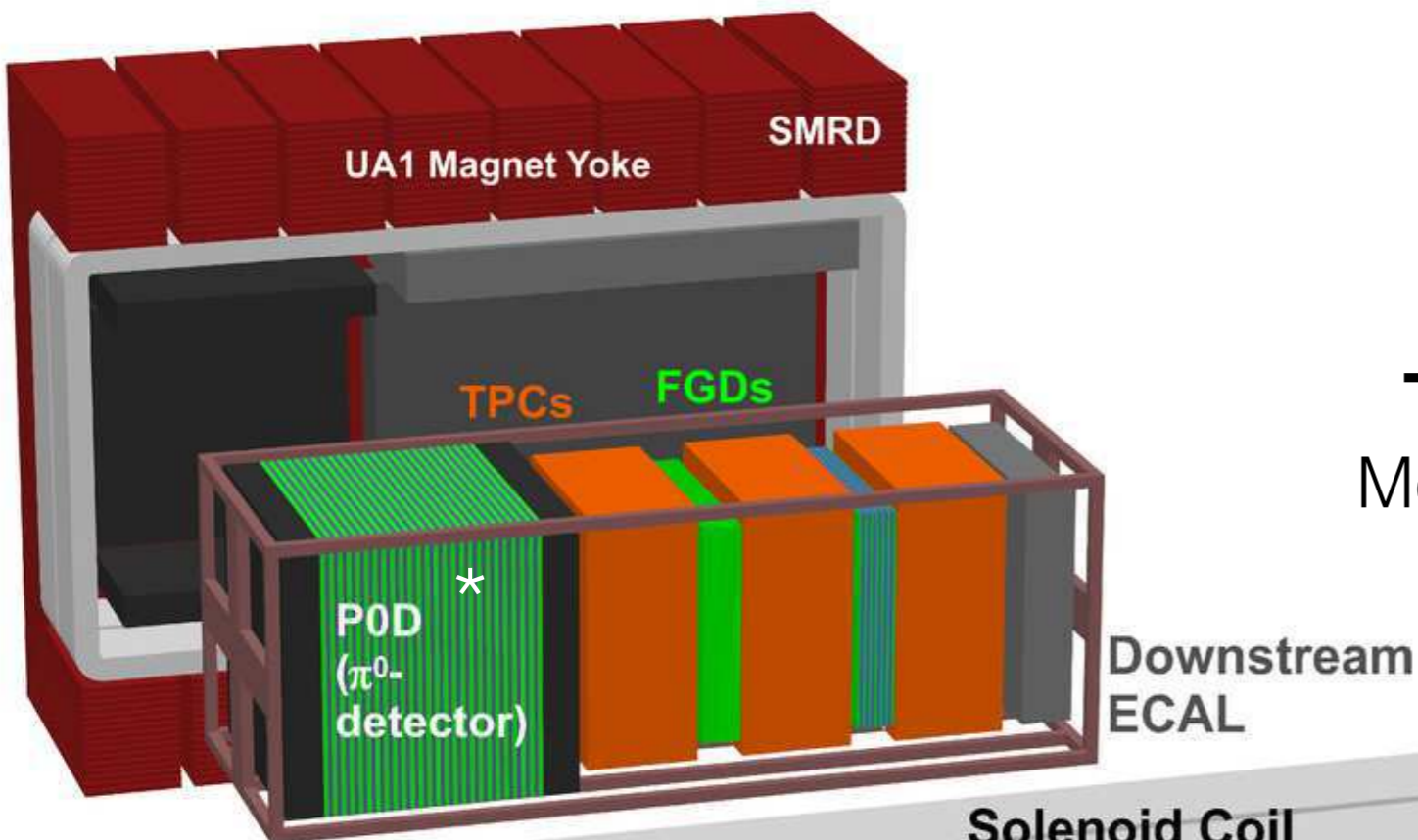

Fine Grained Detectors (FGD)
Carbon and Oxygen Target Mass,
Vertex reconstruction

Time Projection Chambers (TPC)
Momentum and Charge Measurement
Particle ID

EM Calorimeters
Neutral Particle Reconstruction
Additional PID and
energy measurement
Tag entering backgrounds

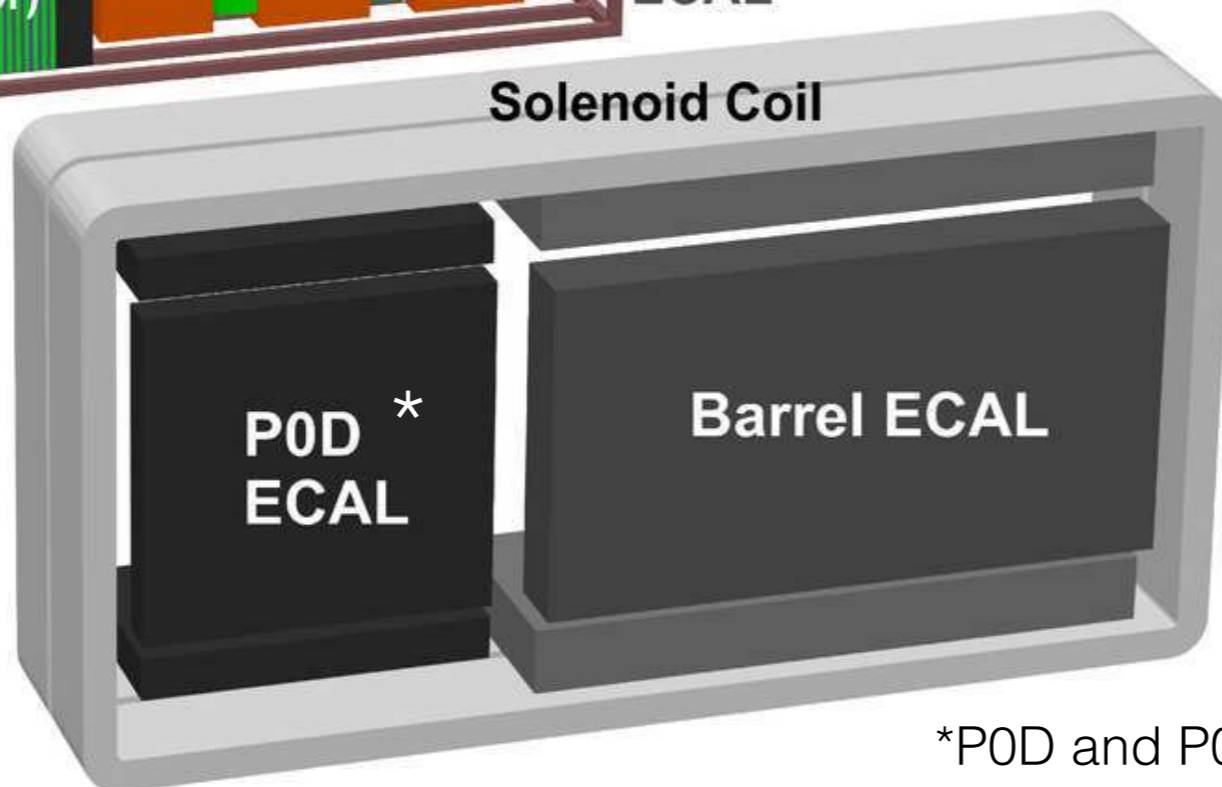
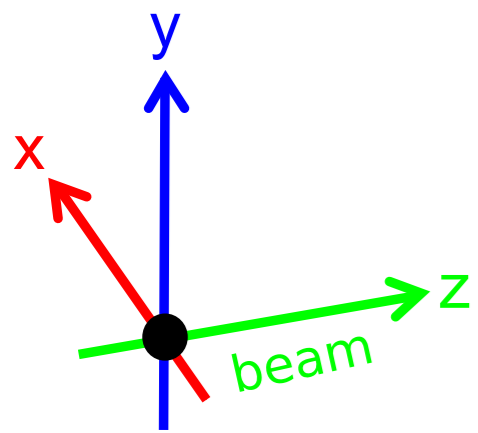

*P0D and P0D ECAL detectors not be discussed here.
See arXiv:1111.5030 and arXiv:1308.3445 for information on these detectors.

ND280 Input to T2K Oscillation Analysis

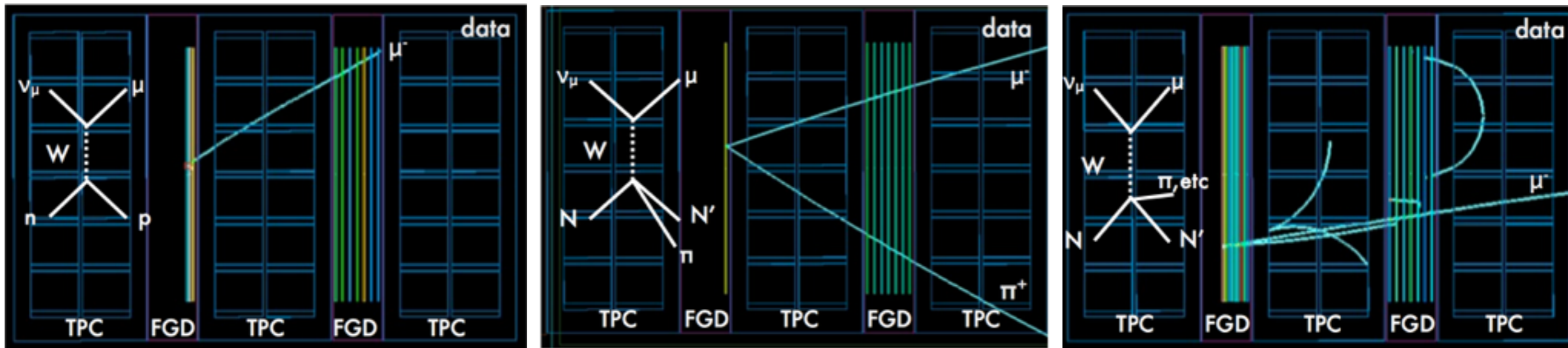

ND280 data split based on reconstructed topology enhanced in different interaction types

Fit flux + interaction model and propagate to far detector

As statistics increase and analysis becomes more sophisticated incorporate more channels

ν_e Event Displays

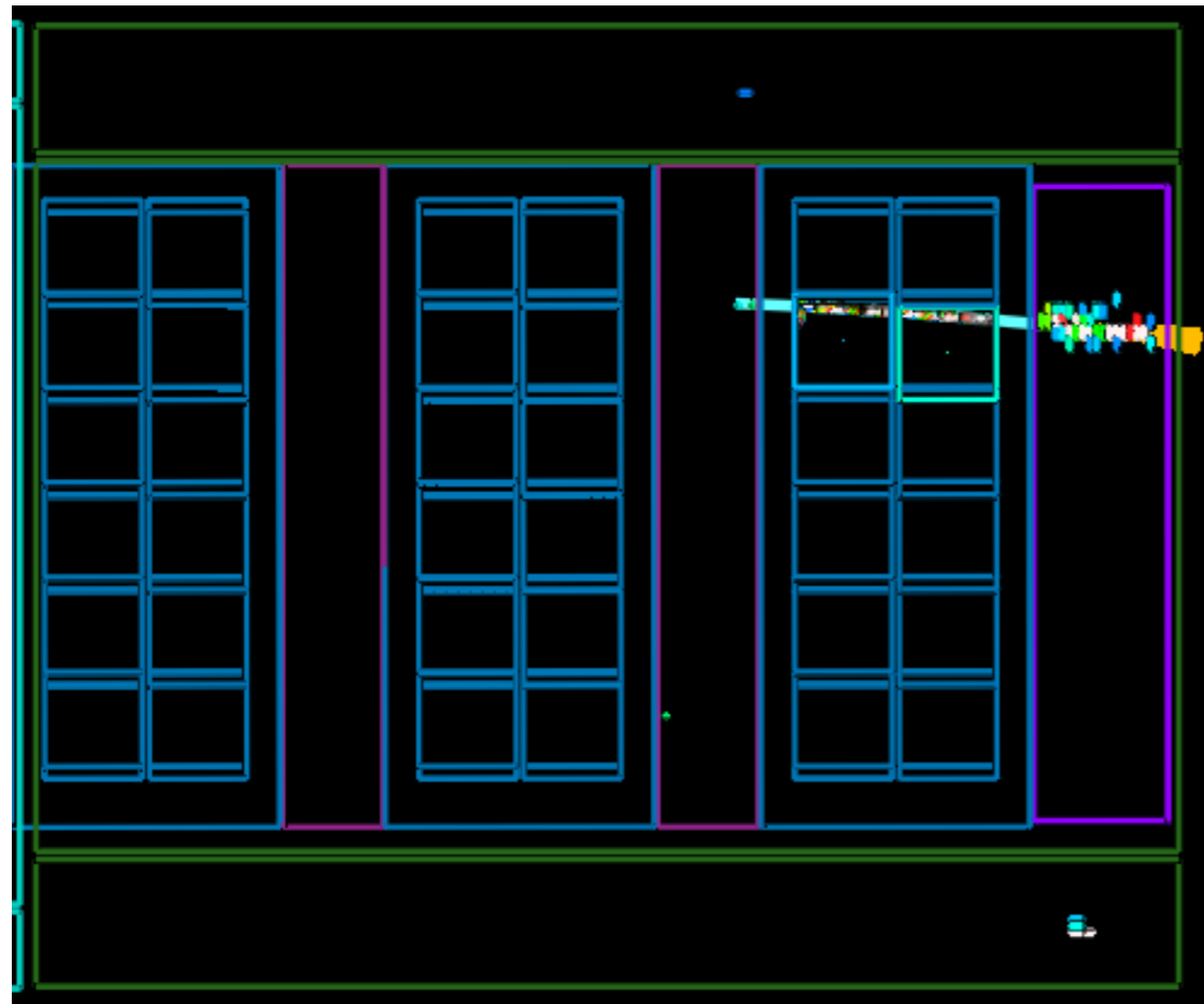

T2K-TN-149

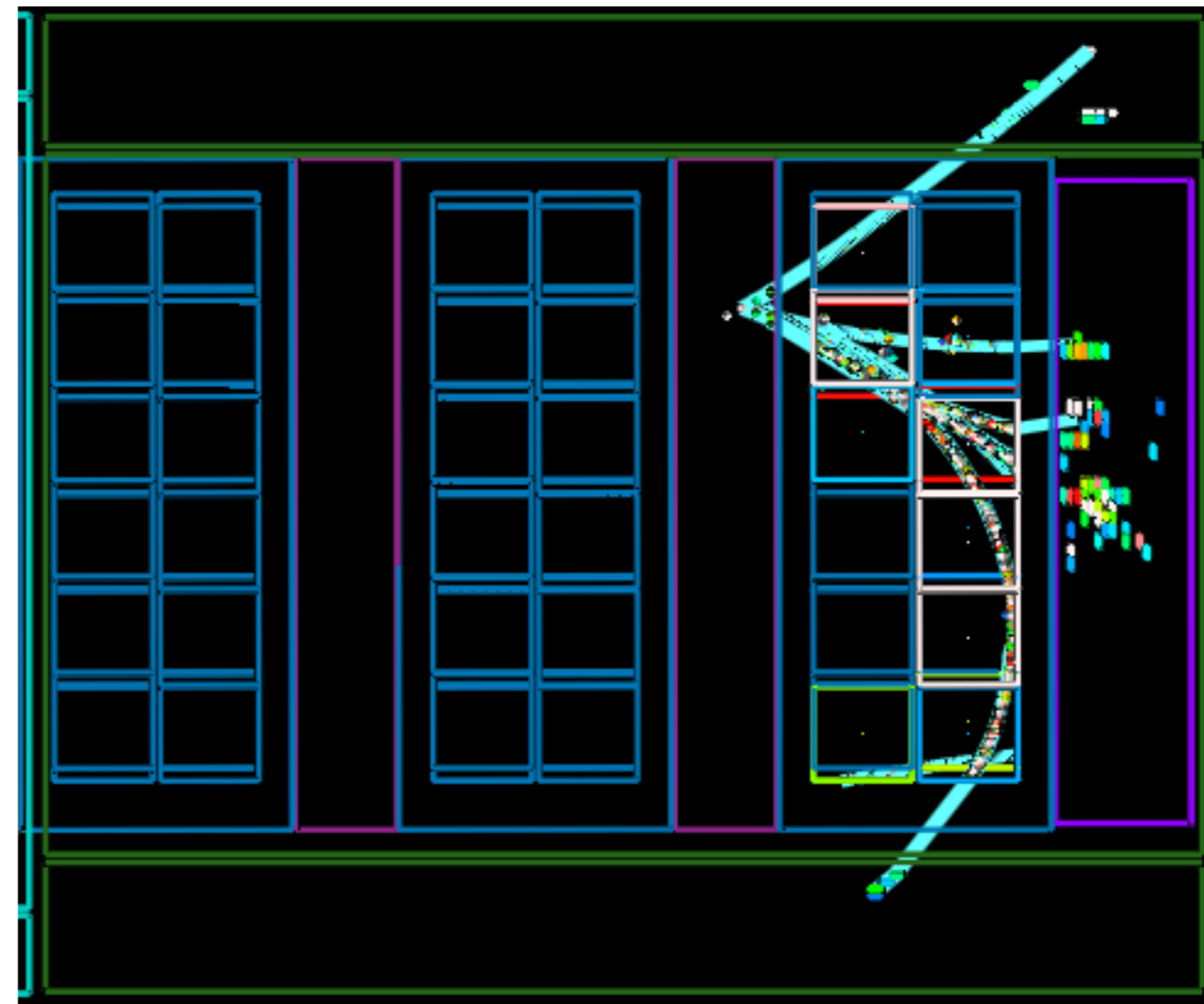

T2K-TN-149

Anti- ν_e Event Displays

